



Your easy way to space.



Space-Friendly™
Digital CubeSat Dosimeter
piDOSE-DCD

Product Datasheet

Rev. A/2026

Intended for **small satellite science**.

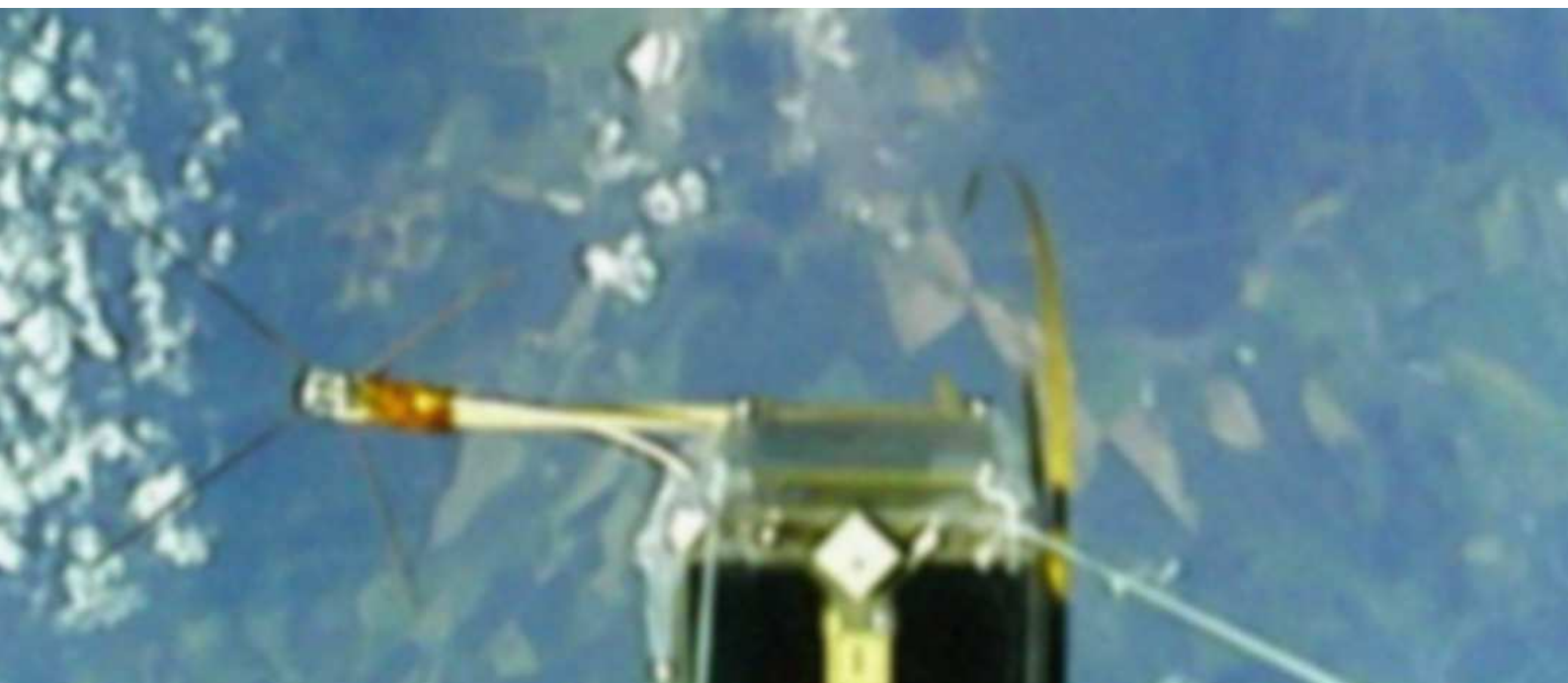

PRODUCT DATA SHEET

piDOSE-DCD

FEATURES

- World's First Digital CubeSat Dosimeter
- Geiger Counter with no high voltage parts
- Simple to use, no settings needed
- No optical window or dust-sensitive aperture
- Radiation Alarm signal – triggered over 40 $\mu\text{Sv/h}$
- Alarm reaction time
 - Activation (>40 $\mu\text{Sv/h}$) over 1 second
 - Deactivation (0-40 $\mu\text{Sv/h}$) over 1 second
- Trigger equals to 2x ISS Average Dose Rate
- Serialized Digital Dose Rate output
- Measurement range 0.01 to 9000 μSv
- Error signal indicating
 - Overload (ERROR, at more than 9 mSv/h)
 - zero Counts Per Minute
 - temperature over -30°C to 60°C
- Power consumption
 - 70 mW (typical), 5 V @ 25°C
- Sensitive to gamma and high energy beta rays
- Gamma Ray Sensor operating range
 - ~0.2 – 10 MeV
- Photon wavelength converter sensitive volume
 - 250 mm³
- Easy-to-Implement Data Interface
 - UART 115200-8-N-1, 5V-CMOS levels
- 10x Serial Output sentences, divided by CR+LF
 - 6x Counts per 10 seconds
 - 1x Temperature telemetry
 - 1x Voltage telemetry
 - 1x Uptime telemetry
- Digital Output with fixed pulse width
- Total Ionizing Dose tolerance less than 10 kRad(Si)
- Analog Output with ~energy-dependent width
- Interrupt signal indicating serial stream
- External Reset input
- Power Supply input
 - +2.7 to +5.5 V
- Ultra Low Dimensions
 - 53x32x(+14, -1) mm
 - STEP model available
- Low Package Mass: 32 grams only
- Wide operating temperature range
 - 30°C to +60°C
- Connector
 - 2 mm pitch, 2x5 pin header

APPLICATIONS

- Space or Terrestrial Radiation Monitoring
- Aircraft Onboard Radiation Monitoring
- Civil Scientific High Altitude Balloons
- Educational Toolkit, Pfozter Maximum Monitoring
- Radiation Mapping in 3D together with GNSS
- Space Weather Monitoring

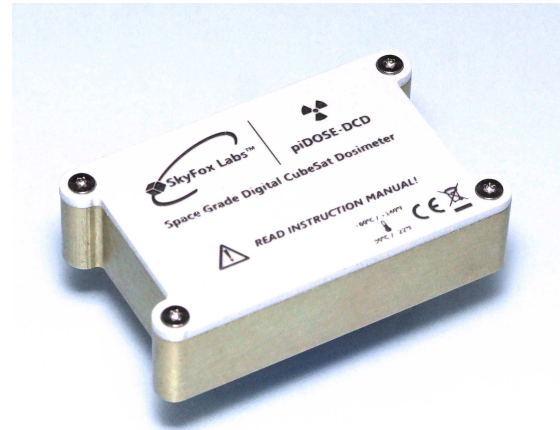

Fig. 1 Digital CubeSat Dosimeter piDOSE-DCD, Flight Model.

GENERAL DESCRIPTION

The piDOSE-DCD is the World's First Space-Friendly™ Digital CubeSat Dosimeter specially designed to provide the information about local gamma ray radiation background aboard small satellite in space based on ten seconds and minute period measurements without the need of high voltage Geiger-tube sensors.

The PIN diode solid state radiation sensor is equipped with scintillation crystal to extend the lateral sensitive volume to almost omnidirectional and wider energy range (~0.2 - 10 MeV).

The unit contains electrical outputs to signalize the Alarm threshold reached (similar to two times the ISS average dose rate), ERROR signal in case of sensor overload (overdose), INTERRUPT signal to signalize UART data packet transfer, Digital Counts Per Minute pulse output with equalized pulse width and Analog Counts Per Minute Output from the analog comparator.

There are six packets sent about counts per 10 second period, followed by a summary packet indicating doserate integrated over past 60 seconds added with telemetry information (voltage, temperature, uptime).

TABLE OF CONTENTS

APPLICATIONS.....	2	OUTPUT DATA DESCRIPTION	7
GENERAL DESCRIPTION.....	2	EXAMPLE DATA OUTPUT PER ONE MINUTE PERIOD	8
TABLE OF CONTENTS	3	TIMING DIAGRAM.....	11
ABSOLUTE MAXIMUM RATINGS	3	EVALUATION KIT	11
PARAMETRIC SPECIFICATION	3	APPLICATION NOTES & RECOMMENDATIONS.....	13
CONNECTORS DESCRIPTION	4	QUALITY ASSURANCE	14
FUNCTIONAL BLOCK DIAGRAM	5	EXPORT CONTROL.....	15
THEORY OF OPERATION.....	5	DISCLAIMER	16
PROTOCOLS.....	6		

ABSOLUTE MAXIMUM RATINGS

V_{DD} to GND.....-0.3 V to +5.5 V Other Pins to GND:..... -0.3 V to +(V_{DD} +0.3) V
 DC Input Voltage: V_I -0.3 V to V_{DD} + 0.3 V (≤ 5.5 V max.)
 DC Output Voltage: V_O-0.3 V to V_{DD} + 0.3 V (≤ 5.5 V max.)
 DC Input Current: I_I at V_I < 0 V or V_I > V_{DD}±20 mA Operating Temperature Range:.....-30°C to +60°C
 DC Output Current: I_O at V_O < 0 V or V_O > V_{DD}.....±20 mA Storage Temperature Range:.....-40°C to +70°C

NOTE: Stresses beyond those listed under “Absolute Maximum Ratings” may cause permanent damage to the device. These are stress ratings only, and functional operation of the device at these or any other conditions beyond those indicated under specification conditions is not implied. Exposure to absolute maximum rated conditions for extended periods may affect device reliability. Voltage values are with respect to system ground terminal.

PARAMETRIC SPECIFICATION

T_A = -30°C to +60°C, V_{DD} = 5 V, unless otherwise noted.

Parameter	Symbol	Min	Typ	Max	Units	Notes/Conditions
Operating Supply Voltage	V _{DD}	2.7	3.3	5.5	V	3.3/5V operations fully tolerant.
Operating Supply Current	I _D		14		mA	
Active Operating Power	P _{Nom}		70		mW	
Alarm Threshold	\dot{D}_{ALARM}		40		μSv/h	Alarm is activated when dose rate more than 40 μSv/h is detected over the period of 1 second. Alarm is deactivated below this threshold during following second. 40 μSv/h is equivalent to twice the average radiation exposure inside of the International Space Station.
Error Threshold	CPM _{ERROR}	0	-	900000	CPM	When 0 or more than 900000 counts were captured during one minute, the error signal goes low. Zero counts point out to CSA saturation, sensor saturation or input circuits damage.
Energy range	E	~0.2		10	MeV	Probability of capture is given by the sensor geometry, cross section and dose rate.
Count rate range (per second)	CPS	1		15000	CPS	Minimum given by signal processing chain over minute. Zero CPM activates error signal.
Dose rate range per hour	\dot{D}	0.01		9000	μSv/h	Maximum dose rate given by system bandwidth.
Basic error of measurement	u		±30		%	Uncertainty is given by probability of capture given by the sensor geometry, cross section and dose rate.
Startup time	T _{STARTUP}	1		3	s	Time for initial packet transmission and proper DC biasing of analog chain. First dose information after next 60 second of measurement.
Interrupt signal pre-/post- timing	T _{INTERRUPT}	80		350	μs	Data is transmitted after the interrupt signal goes low. Interrupt signal goes high after packet is sent within T _{INTERRUPT} time.
Digital CPM Output Signal Width	T _{DIGITAL}	10	50	70	μs	Pulse rising edge triggered signal.
Analog CPM Output Signal Width	T _{ANALOG}	10	50	150	μs	Pulse level triggered signal.
Internal Clock Timebase Oscillator	Xtal		12		MHz	20 ppm Frequency Tolerance + 50 ppm Frequency Stability over the temp. range.
Packet output period	T _{PacketRate}		10		s	Timing derived from crystal oscillator.

CONNECTORS DESCRIPTION

The piDOSE-DCD unit is connected to the target system via the System Interface dual row 2x5 pin connector header with miniature 2 mm pitch passing through the hosting board. Each pin, its function and direction or manner of use is indicated in the Tab.: 1 below. The connector location within the Flight Model is displayed in Fig. 2.

Tab.: 1 **The piDOSE-DCD Pin Description**, NOTE: Minimum required interface pins are highlighted.

Pin	Name	I/O, Power or Do Not Connect	Description
1	VDD	Power	Main Power Input.
2	/INTERRUPT	O	Interrupt Signal Output. In multiplexed systems, this signal may serve as interrupt of the host system. Data packet transmission is announced by INTERRUPT signal low. After the final byte is send, INTERRUPT signal goes high with T _{INTERRUPT} . CMOS compatible.
3	GND	Power	Ground potential. Unit casing (including all screws) is galvanically connected to this pin internally.
4	/ERROR	O	Error Signal Output. Error signal goes low when no or more than 900000 counts per minute period is detected. This may be caused by overloading the input sensor with too high radiation dose. Error signal is announced within 60 seconds period and reset during next period when at least 1 CPM is detected. CMOS compatible.
5	/DIGI_CPM	O	Digital Counting Signal. Output of digital signal processing unit. When gamma ray photon quanta are detected, this pin goes low. Signal is raising edge triggered with fixed width. CMOS compatible.
6	/ALARM	O	Alarm Signal Output. Alarm is activated when dose rate more than 40 µSv/h is detected over the period of 1 second. Alarm is deactivated below this threshold during following second period. 40 µSv/h is equivalent to twice the average radiation exposure inside of the International Space Station. CMOS compatible.
7	/ANALOG_CPM	O	Analog Counting Signal. Output of digital signal processing unit. When gamma ray photon quanta are detected, this pin goes low. Signal is level triggered with energy-dependent width. CMOS compatible.
8	RXD	I	Serial Data Input. Telecommand Input, in format 115200-8-N-1. List of telecommands is summarized in chapter "Output Data Description", Tab.: 2, CMOS compatible.
9	/RESET	I	System reset. Active Low. Internal timing circuitry controls the reset. Pin could be used to force digital signal processing core reset. CMOS compatible. Internal 10 kOhm pullup.
10	TXD	O	Serial Data Output. Data is sent out of this pin in format 115200-8-N-1, with a period of 60 seconds. Interrupt signal is announcing packet transmission before and after data is sent. CMOS compatible.
Chassis	GND	Power	Ground potential. Unit casing (including all screws) is galvanically connected to this pin internally.

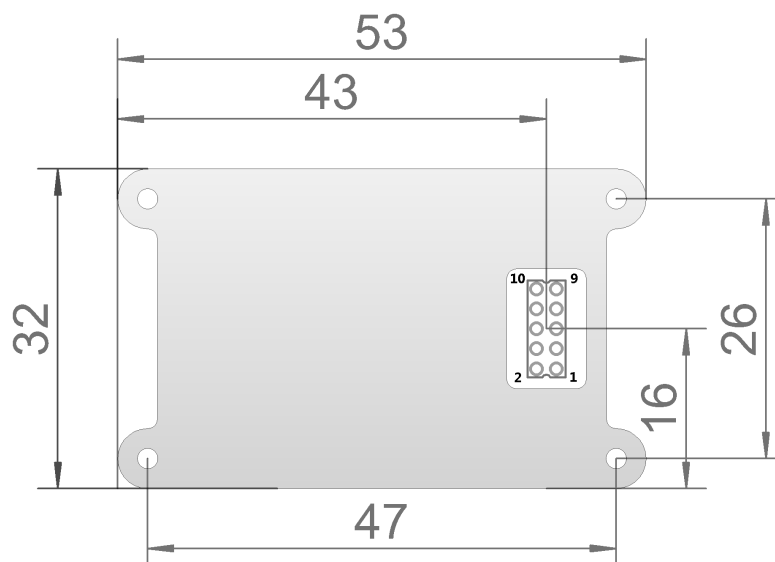

Fig. 2 **The piDOSE-DCD Dimensions, Connector pinout and recommended footprint**. NOTE: The piDOSE-DCD is displayed from the TOP side. Pins from the through hole connector are aiming down through and below the system PCB. The SMD mount connector type HARWIN M22-6360542 is recommended. Dimensions are shown in millimeters. The unit is mount using four M2x8 screws (including 1.6 mm system PCB). Detailed STEP model available.

FUNCTIONAL BLOCK DIAGRAM

The key functional blocks of the piDOSE-DCD are described in Fig. 3. As the radiation monitor is mostly analog-based circuitry, special attention is paid to filter and reject the input voltage bus from high frequency noise to low frequency variations. High speed processes also requires filtering for noise emission, thus also digital electronic power supplies are first properly filtered using active and passive means of filtering.

Input signal is then processed using Charge Sensitive Amplifier (CSA) with very high gain ($3 \cdot 10^7$). *Its gain is high enough to react on audio noise as the sensor area with respect to the housing may act as microphone structure to generate small electric charge during high vibrations. To cover "microphonic effect", the sensor is tightly glued to the PCB and damped using press-sensitive glue to the housing. Moreover, on typical satellite no acoustic vibration levels are present during nominal operations.*

Output of the CSA is then further amplified using zero-pole cancellation amplifier and shaping circuit, then fed directly to Signal Processing Unit. Here count rate is processed and converted to milliSievert per Hour information. All output signals are based on further signal processing inside of the Signal Processing Unit.

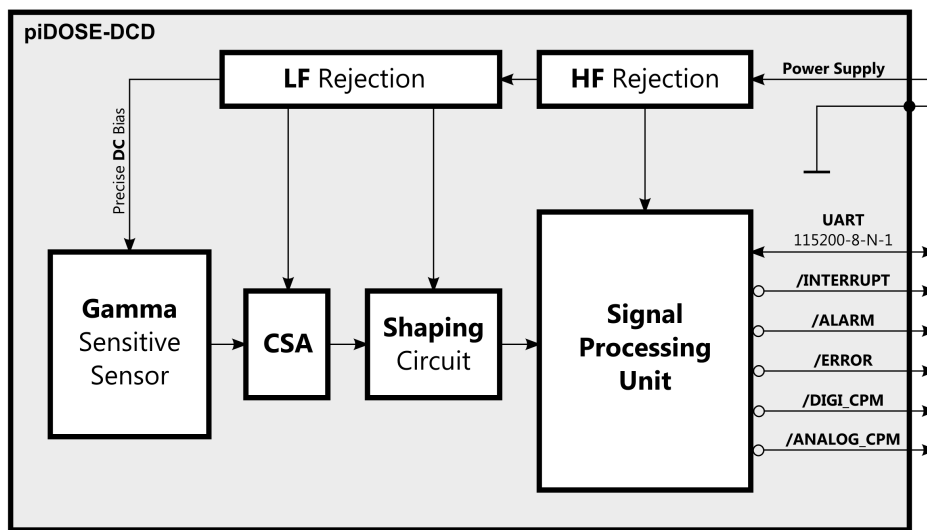

Fig. 3 The piDOSE-DCD Block Diagram.

THEORY OF OPERATION

In vacuum of space satellites are faced to increased radiation exposure with respect to terrestrial regions protected mainly due to interaction with Earth’s magnetosphere and atmospheric attenuation. Orbiting satellites are exposed to Galactic Cosmic Rays (GCR), Solar events such as Coronal Mass Ejections or trapped particles in inner and outer Van Allen Radiation belts (depending on orbit altitude, proton or electron in majority).

As the geomagnetic field plays significant role in particle trapping and shielding the Earth, different radiation exposures are absorbed by satellite systems depending on orbital altitude, inclination, eccentricity and of course lifetime or stage of solar cycle.

The most radiation damage is caused at low to mid energies (1-10 MeV) due to the property to influence the matter structure or even end up inside of it (silicon material doping). Especially, trapped charged particle deposited due to interaction of incident ionizing particle radiation or high energy gamma radiation followed by secondary emission including gamma ionizing radiation affects the charge applied to conductive channel inside Field Effect Transistor (FET) structures and controlling it without applied gate-source voltage.

The SiO₂ silicon oxide insulation barrier is present in any MOSFET structure such as CMOS logic. Deposited charge influencing the electric field inside of the FET conductive channel controls the channel width and thus also a total channel cross-section and conductivity. As such trapped charge could not be removed from the insulator; it is very difficult to get back the full control over the transistor’s conductivity. Moreover, the doping suffers from cumulative effect (cumulative dose or total ionizing dose). Under certain conditions, thermal stress releases these charge impurities. Such process called annealing however may not recover the full component functionality.

From above mentioned follows that from certain energies and up, the probability of radiation damage is not as high as at low energies (below ~10 MeV). Particle simply penetrates through causing almost negligible matter damage ("shoot through"). Furthermore, higher energy particle probability of interaction with semiconductor decreases due to its inverse proportional distribution in space vs. energy (\uparrow energy vs. \downarrow amount).

In contrary to particle radiation, gamma rays act as ionizing radiation which extracts electrons from their positions in atoms and changes the total electric field distribution in FET channel again. It means, different type of radiation source causes very similar final effect – irreversible loss of conductivity control in transistors.

Because the piDOSE-DCD is not intended to serve as spectrum analyzer (spectrometer) to discriminate between type of radiation sources, radiation energies or even direction of impacts, the output is delivered as a scalar value of dose rate per hour.

Silicon-based sensor with active area of 100 mm² is equipped with photon wavelength converter increasing sensitive volume up to 250 mm³. Converter is used to adapt the sensor from mostly two dimensional to three dimensional registering space. Additionally, sensor is installed inside of the aluminium shielding box acting as the EMI faraday cage, ambient light shield and also bremsstrahlung generator for easier registration of particle radiation. Secondary hard x-rays (photons) might be then registered. Charged particle radiation (i.e. except neutrons) are registered as far as they are able to deposit a sufficient amount of charge change inside of the silicon PIN diode depletion region or if their interaction with unit housing is accompanied with gamma rays.

The sensor chip main charge collecting area is mounted inside of the piDOSE-DCD in horizontal position, parallel with target board where other circuits are soldered to represent as much similar as possible the impact of radiation damage.

Satellite orbiting the Earth may pass regions of suddenly increased radiation exposure as for example inside of the South Atlantic Anomaly, where geomagnetic field goes very low above the ground, bringing radiation cloud closer to the earth and thus closer to the satellite, when it is placed in LEO (200-500 km region). Change of radiation dose rate may be in 3-4 orders of magnitude with respect to the rest orbital region, lasting from several up to 15-20 minutes, depending on orbital parameters. Intensive radiation change is registered within one second and triggers the alarm signal, when the counts per second (CPS) increases to a level of ~70 and more. Such condition is indicated by activating /ALARM (log. 0) signal output.

PROTOCOLS

The physical communication is realized via the standard UART data interface. The baud rate is set to **115200 bps, no parity, 8 data bits, 1 stop bit (115200-8-N-1)**. Logical levels are equal to CMOS levels as defined in JEDEC JESD8C.01 standard. The piDOSE-DCD provides serialized stream of measured radiation data (sentence number 0) approx. 11.2 seconds after the unit startup / power cycle / reset. Note, approximately 1.2 seconds is internally necessary to stabilize all internal capacitances/voltages, then the first measured sentence is provided in 10 seconds, thus resulting in 11.2 seconds. Initial info/product FW version text is provided immediately after unit startup / power cycle / reset. For the text see the chapter: EXAMPLE DATA OUTPUT PER ONE MINUTE PERIOD.

The unit does not need any telecommand to automatically produce the measured data/sentences, thus the RXD pin can be also left unconnected. Check the list of telecommands for other functionalities accessible via RXD pin, most of them are used to get the data/sentences "on demand" or anytime, instead of waiting for their standard release during each 10 seconds period.

The /ALARM signal is triggered (goes log. 0) within 1 second period after calculating the amount of radiation within 1000 ms time. It is released (goes log. 1) 1 second after the radiation goes below the threshold. It means, it is not tight together with 60 seconds measurement period, but reacts instantaneously on 1 second basis.

The /ERROR signal is triggered (log. 0) after nominal 60 second measurement period as a result of no radiation detected or detected more than 9 mSv/h. Both however may be caused by overloading in case of very high radiation background. After the overloading is not detected, /ERROR signal goes back again (log. 1) in next 60 seconds period.

Each data packet sent out of the piDOSE-DCD is accompanied with /INTERRUPT signal announcing upper level system about the planned, progressing and ended serial stream using log. 0. This signal may be used for upper level multiplexing of UART bus in case of sharing with multiple users. At least 100 μ s is provided prior and after the serial stream on /INTERRUPT signal.

OUTPUT DATA DESCRIPTION

The dosimeter provides serialized information about the ambient radiation situation in miliSieverts per hour format. As extension, each 10 seconds a datagram containing counts per 10 seconds information is provided periodically (i.e. 6 datagrams of counts per 10 seconds, per minute period), followed by summary doserate (mSv/h) sentence, temperature measurement sentence (°C), voltage measurement sentence (V) and the unit uptime sentence (s). Output is represented by conventional ASCII character form and thus could be easily displayed using computer with any serial terminal software for COM port data reception.

The physical communication is realized via the standard bidirectional UART data interface. The bitrate is set to **115200 bps, no parity, 8 data bits, 1 stop bit (115200-8-N-1) as default after each successful unit boot-up/reset**. Logical levels are equal to LVCMOS levels as defined in JEDEC JESD8C.01 standard.

Telecommanding is realized based on a set of single byte commands as summarized in Tab.: 2. There is a total of six commands for providing internal dosimeter information on demand. Case sensitivity is not implemented, thus the user can send the command in lower or upper case of the same "ASCII" letter. Hexadecimal representation of the command is mentioned in brackets.

In order to discriminate between autonomously transmitted sentences from the unit out of those sent upon telecommand, the user can recognize that the autonomous sentences are provided with decimal numbering, whilst the response sentences to telecommands are initiated with associated upper-case letters, except for the command "N", "n", (0x6E), (0x4E) for restarting the internal registers in order to keep any internal delays to minimum. Each output sentence has a fixed length, according to its respective purpose, i.e. in case of temperature, the +1°C is indicated as +01°C, -1°C as -01°C and 0°C as +00°C, respectively.

Tab.: 2 piDOSE-DCD Set of single byte Telecommands summary.

ASCII Character (HEX)	Command Description
Data Telecommand	
d (0x64)	Returns last integrated doserate value calculation. Sentence can be recognized with character "D" designator.
D (0x44)	Returns last integrated doserate value calculation. Sentence can be recognized with character "D" designator.
Reset Telecommand	
n (0x6E)	Resets all internal registers and restarts the 1 minute measurement period. Command with no return sentence.
N (0x4E)	Resets all internal registers and restarts the 1 minute measurement period. Command with no return sentence.
r (0x72)	Unit software initiated reset by watchdog activation. Watchdog test. Reset occurs after ~8 seconds.
R (0x52)	Unit software initiated reset by watchdog activation. Watchdog test. Reset occurs after ~8 seconds.
Telemetry Telecommand	
u (0x75)	Returns the total uptime information in seconds. Sentence can be recognized with character "U" designator.
U (0x55)	Returns the total uptime information in seconds. Sentence can be recognized with character "U" designator.
t (0x74)	Returns actual internal unit temperature in deg. C. Sentence can be recognized with character "T" designator.
T (0x54)	Returns actual internal unit temperature in deg. C. Sentence can be recognized with character "T" designator.
v (0x76)	Returns actual bus voltage measurement in Volts. Sentence can be recognized with character "V" designator.
V (0x56)	Returns actual bus voltage measurement in Volts. Sentence can be recognized with character "V" designator.

DIGITAL OUTPUT EXAMPLE (6 Datagrams per minute), sentences number 0 to 5, 18 bytes

`$x;000012 CP/10s←↵`

- \$ packet initial character (0x24h)
- x decimal number indicating the order of the datagram (0 to 5), characters (0x30h to 0x35h)
- semicolon character (0x3Bh)
- n where *n* means representative counts per 10 seconds, number is in decimal form (i.e. number 0 is represented by 0x30h byte), fixed length
- n
- n
- n
- n
- n
- (space) space character (0x20h)
- C C character (0x43h)
- P P character (0x50h)
- / / character (0x2Fh)
- 1 1 character (0x31h)
- 0 0 character (0x30h)
- s s character (0x73h)
- ← CR character (0x0Dh)
- ↵ LF character (0x0Ah)

DIGITAL OUTPUT EXAMPLE (1 Datagram per Minute), sentence number 6, 18 bytes

\$6; 0.00012 mSv/h ← ↵

\$	packet initial character (0x24h)
6	character six, (0x36h), (or D as a response to Doserate command)
;	semicolon character (0x3Bh)
n	where <i>n</i> means representative order of milliSievert per hour doserate, number is in
.	decimal form (i.e. number 0 is represented by 0x30h byte), fixed length, including point
n	
n	
n	
n	
n	
(space)	space character (0x20h)
m	m character (0x6Dh)
S	S character (0x53h)
v	v character (0x76h)
/	/ character (0x2Fh)
h	h character (0x68h)
←	CR character (0x0Dh)
↵	LF character (0x0Ah)

DIGITAL OUTPUT EXAMPLE (1 Datagram per Minute), sentence number 7, 10 bytes

\$7; +20°C ← ↵

\$	packet initial character (0x24h)
7	character seven, (0x37h), (or T as a response to Temperature command)
;	semicolon character (0x3Bh)
s	where <i>s</i> means sign + or - (0x2B), (0x2D), respectively
n	where <i>n</i> means internal temperature of the unit in degrees Celsius doserate, number is in
n	decimal form (i.e. number 0 is represented by 0x30h byte), fixed length
°	degree character (0xB0h)
C	C character (0x43h)
←	CR character (0x0Dh)
↵	LF character (0x0Ah)

DIGITAL OUTPUT EXAMPLE (1 Datagram per Minute), sentence number 8, 10 bytes

\$8; 4.95 V ← ↵

\$	packet initial character (0x24h)
8	character eight, (0x38h), (or V as a response to Voltage command)
;	semicolon character (0x3Bh)
n	where <i>n</i> means value of internal bus voltage measured, number is in decimal form (i.e.
.	number 0 is represented by 0x30h byte), including point, fixed length
n	
n	
(space)	space character (0x20h)
V	V character (0x56h)
←	CR character (0x0Dh)
↵	LF character (0x0Ah)

DIGITAL OUTPUT EXAMPLE (1 Datagram per Minute), sentence number 9, 16 bytes

`$9;00015300 s ←↵`

\$	packet initial character (0x24h)
9	character nine, (0x39h), (or U as a response to Uptime command)
;	semicolon character (0x3Bh)
n	where <i>n</i> means total device uptime in seconds, number is in decimal form (i.e. number 0
n	is represented by 0x30h byte), fixed length
n	including point
n	
n	
n	
n	
n	
n	
(space)	space character (0x20h)
s	s character (0x73h)
←	CR character (0x0Dh)
↵	LF character (0x0Ah)

DIGITAL OUTPUT EXAMPLE (1 Datagram on demand), Reset command response, 11 bytes

`$R;RESET. ←↵`

Note: Reset command activates the internal hardware watchdog to time-out. Restart occurs after ~8 seconds.

EXAMPLE DATA OUTPUT PER ONE MINUTE PERIOD

(Data listed below are collected ~approx. 61.2 sec. since the unit startup)

```

←↵
|=====|←↵
|  piDOSE-DCD v1.7  |←↵
|  Flight Model  |←↵
| (c) SkyFox Labs, 2025 |←↵
|=====|←↵
←↵
$0;000001 CP/10s←↵
$1;000000 CP/10s←↵
$2;000002 CP/10s←↵
$3;000003 CP/10s←↵
$4;000000 CP/10s←↵
$5;000001 CP/10s←↵
$6;0.00007 mSv/h←↵
$7;+20°C←↵
$8;4.95 V←↵
$9;00000060 s←↵

```

EXAMPLE HIGH ALTITUDE BALLOON (HAB) DATA OUTPUT

The plot in Fig. 4 shows data from the high altitude balloon test flight, identifying Pfozter maximum at an altitude of 17000 meters, in both climbing (green) and descent (blue).

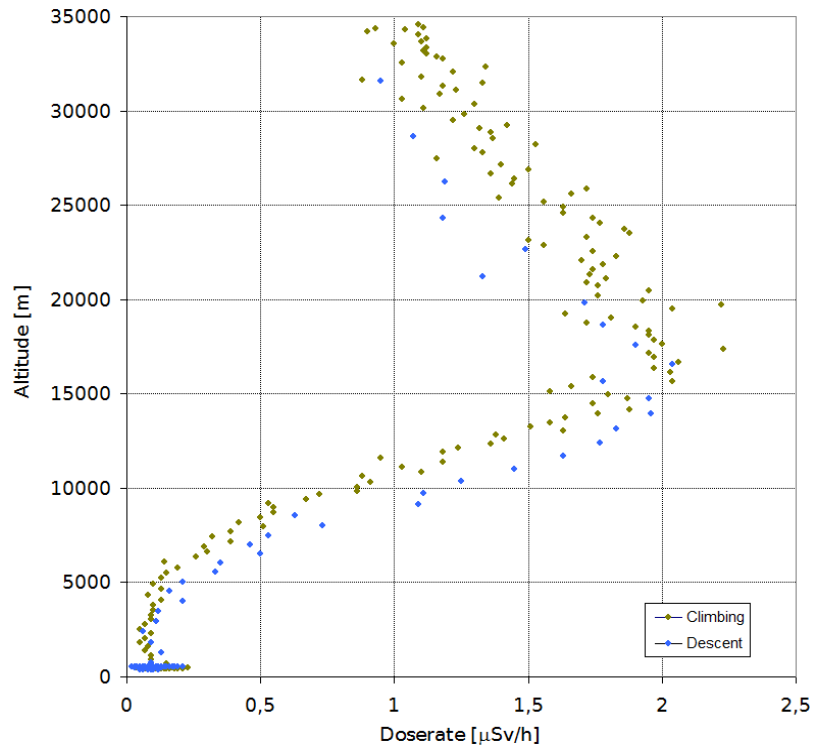

Fig. 4 High Altitude Balloon flight data. Pfozter maximum identification. [Laifr et. al., 2018]

EXAMPLE SUN SYNCHRONOUS ORBIT DATA OUTPUT

The plot in Fig. 5 shows data from the Sun Synchronous Orbit (SSO) 530 km flight of the Lucky-7 spacecraft (NORAD ID 44406), identifying north and south pole aurora ovals and South Atlantic Anomaly (SAA).

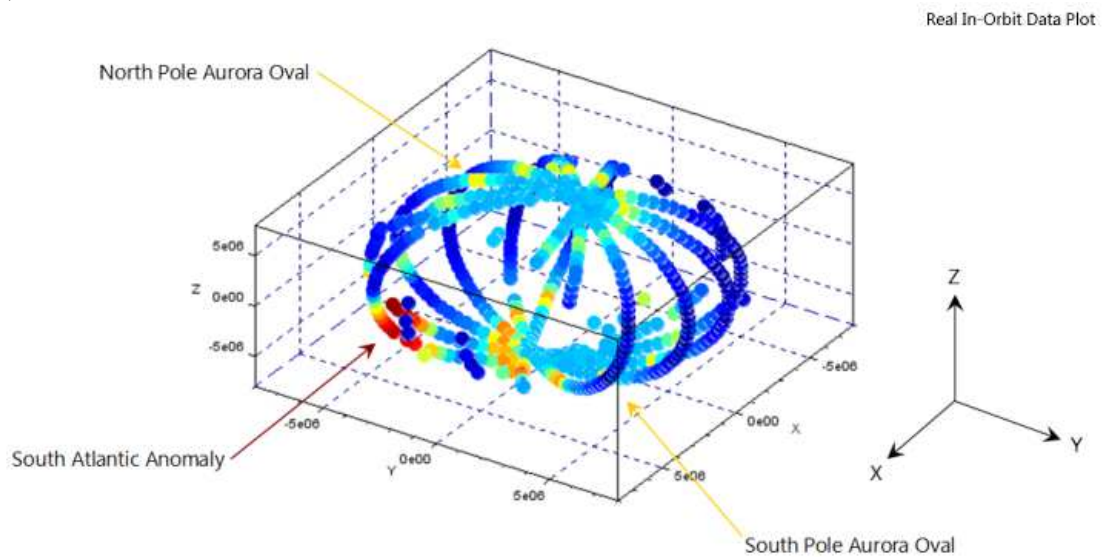

Fig. 5 Dosimetry measurement plot, Sun Synchronous Orbit. [Lucky-7 Spacecraft mission].

TIMING DIAGRAM

Serialized data is available at the TXD output pin as per timing in Fig. 6. Packet transmission is notified by /INTERRUPT signal. No commanding or setting is needed to use the piDOSE-DCD. Data received on RXD pin are ignored and serves for future use.

Incoming radiation is represented by Digital and Analog outputs. /DIGI_CPM provides with 50 us pulse, whilst /ANALOG_CPM output is provided using analog comparator and associated with detected pulse width.

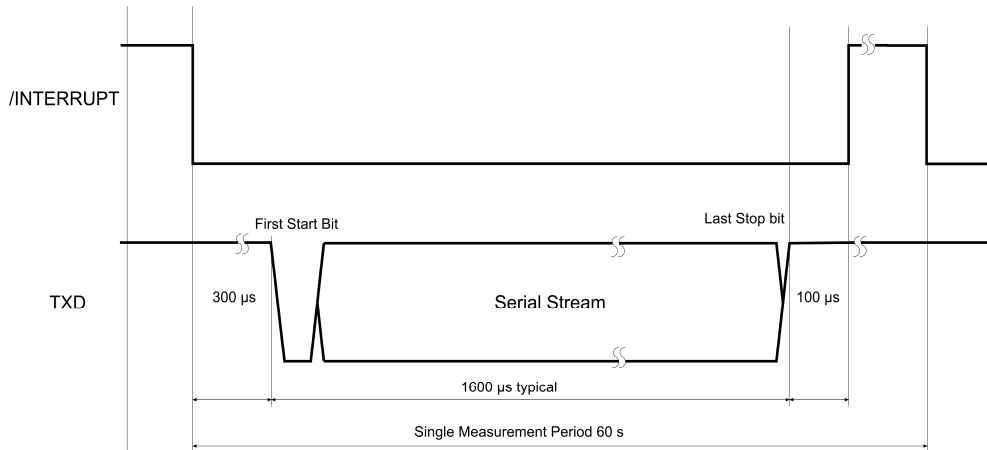

Fig. 6 The piDOSE-DCD /INTERRUPT and TXD output signals timing diagram, single measurement period shown.

EVALUATION KIT

The piDOSE-DCD Evaluation Kit in a standard PC/104+ PCB form factor in Fig. 7 has been developed to support the piDOSE-DCD implementation together with the serial data parsing and signal recognition software development in engineering and breadboarding phases. It enables user to easily connect and power the unit from the USB, collect the data and uplink telecommands over the serial link established by the FTDI Serial-to-USB cable associated with the Eval Kit product package. Current consumption measurement and output data waveforms can be captured by conventional ammeter and scope using current sensing and serial port pin headers.

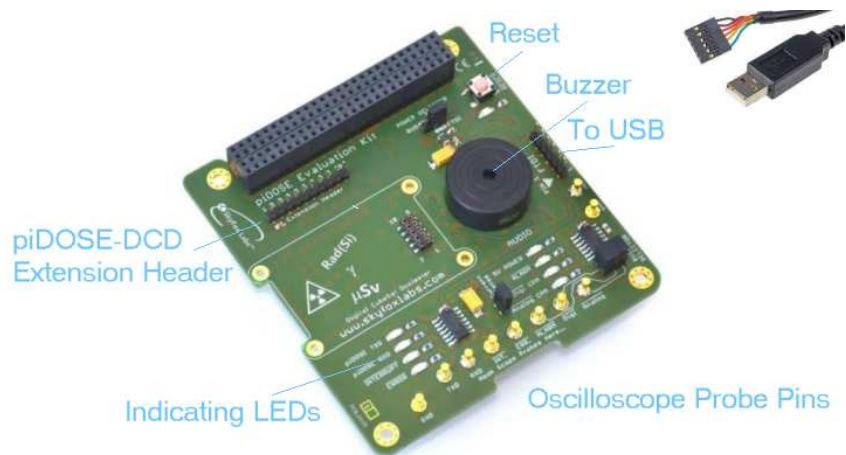
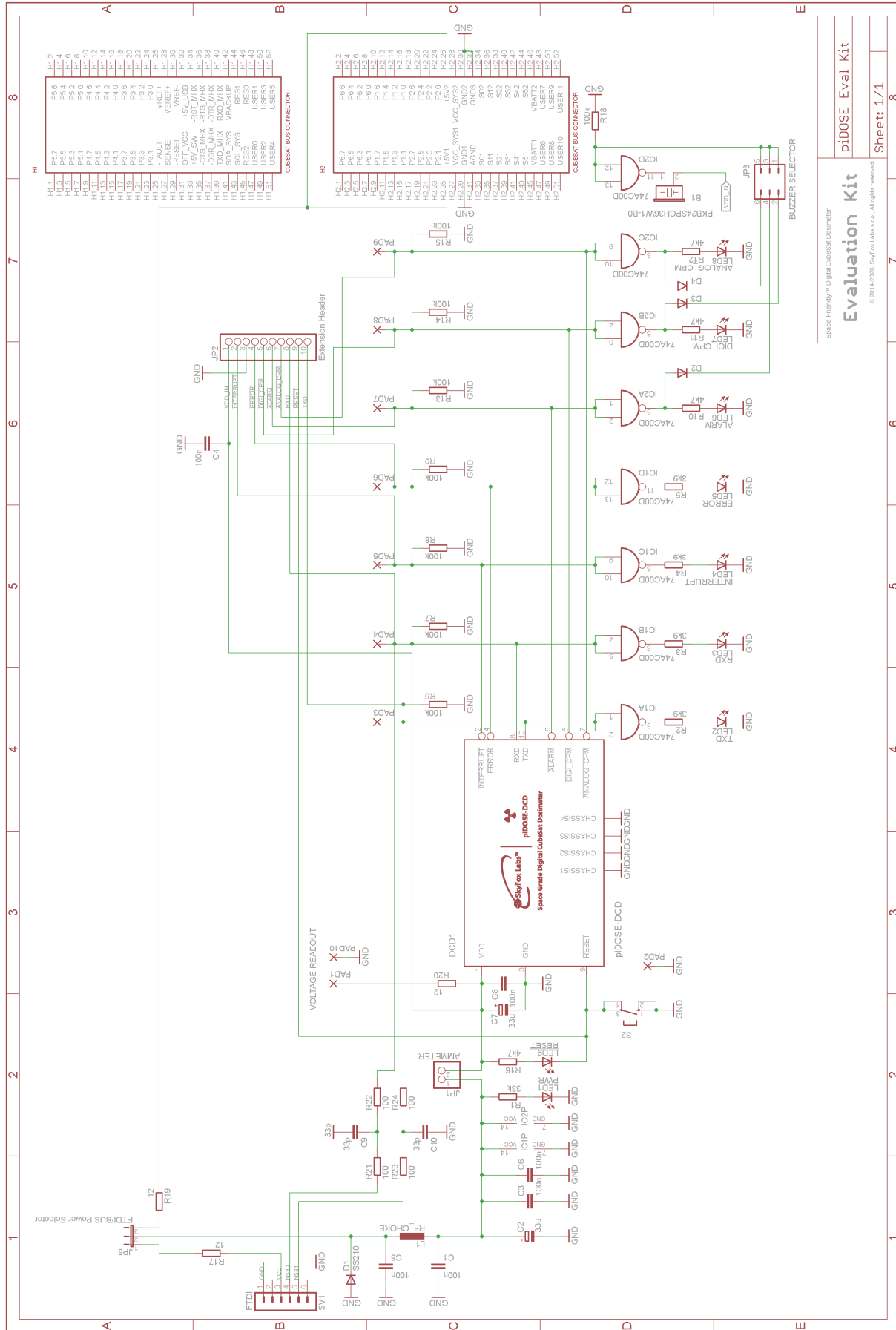

Fig. 7 The piDOSE-DCD Evaluation Kit.

For the piDOSE-DCD data parsing purposes the piDOSE-DCD Digital CubeSat Dosimeter Eval Kit Demo Software application for Windows® environment has been developed. The program can visualize the trend of all the measured values and display the unit activity, such as the voltage, temperature or uptime in seconds. In Fig. 8 the screenshot of the active application is provided, showing all functions and controls which can be utilized to communicate with the piDOSE-DCD unit. The Kit schematics is mentioned for reference.



Space-Friendly™ Digital Cubesat Dosimeter
Evaluation Kit
 © 2014-2026, SkyFox Labs s.r.o., All rights reserved.
 Sheet: 1/1

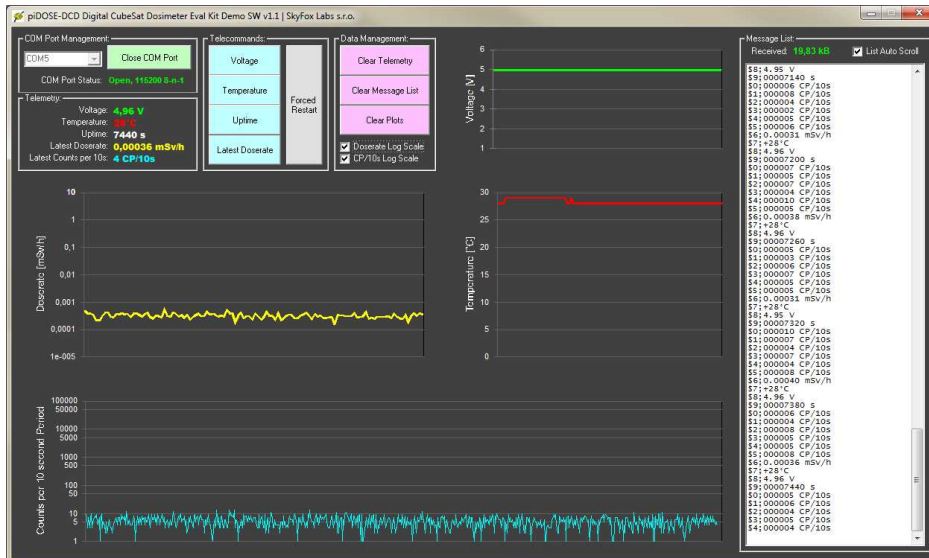

Fig. 8 piDOSE-DCD Digital CubeSat Dosimeter Evaluation Kit Demo Software application.

APPLICATION NOTES & RECOMMENDATIONS

EMC CONSIDERATIONS

The electromagnetic susceptibility and compatibility is critical for implementation of any subsystems sensitive to electromagnetic radiation. Proper ground planes and PCB design rules minimizing the radiated and conducted emissions shall be applied within the whole small satellite structure, including custom payloads, conventional (Communication and Data Handling, Power Supply and Power Distribution, Onboard Computer, Attitude Determination and Control) and third party electronic subsystems.

Using many decades of dB attenuations in both HF and LF rejection filters, the piDOSE-DCD is well insensitive to power line noise and variations. However keep the noise 100 mV_{pp} or lower voltage variation at frequencies from 1 kHz and up is recommended. Screw head from bottom side of target PCB shall be galvanically connected with ground potential. GND potential is already connected between electronic board and casing.

SENSOR LOCATION

Sensor is located within the volume of the aluminium housing as depicted in Fig. 9. In uniform radiation background such as in space, the sensor position or orientation with the satellite is not critical, except the different satellite body materials. Although the unit housing works as the Faraday cage to minimize disturbing electric fields, there might be possible to induce a false pulses registration on the sensor CSA input via magnetic coupling. Such magnetic pulses could be caused by high current pulses routing aboard the satellite, such as during onboard radiomodem transmission periods. *It is recommended to check the natural radiation background output data obtained using the standalone piDOSE-DCD Evaluation Kit and compare it with the same test site of the sensor implemented in fully operational satellite body during the Assembly Integration and Verification/Test activities to prevent false pulse counts outputs.*

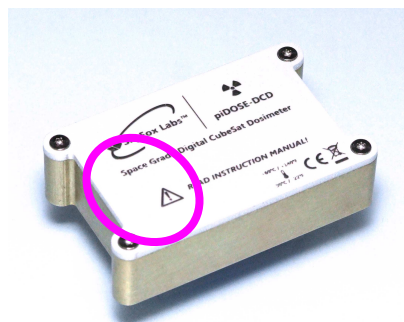

Fig. 9 Sensor location depicted on the left side of the piDOSE-DCD casing.

QUALITY ASSURANCE

GENERAL INFORMATION

Since the piDOSE-DCD has been designed for the operation in space environment as a specially featured electronic device based on Commercial Off-the-Shelf (COTS) components, the special care is taken to follow the standardized space-grade product assembly procedures, materials and components where possible (i.e. no Radiation Hardened integrated circuits or parts are used). It is recommended to control the possible single event latchups of the unit based on overcurrent/overload monitoring on the unit main power input.

MATERIALS

Components are soldered on the 2-layers FR4 PCB, using 60/40% (Tin/Lead) compound. White PCB conformal coating surface finish is used to stabilize extra low leakage currents and prevent outgassing. The NASA approved 3M Scotch Weld Epoxy adhesive is used for radiation shielding screws and components fixings. The aerospace-grade NC-machined 6061-T6 Aluminium alloy is used for the product housing.

Vacuum-proof electronic components from ESA and NASA-preferred vendors are used (i.e. no electrolytic capacitors) in industrial temperature grade, where possible.

PROCESSES

The Flight Model is hand soldered, assembled in 100.000 Class Clean Room by the ESA-certified personnel. The PCB is then cleaned using the Isopropyl Alcohol, programmed and tested. Post production burn-in screening test is performed for 96 hours under nominal operating conditions.

PACKAGING & SHIPPING

Once the piDOSE-DCD successfully passes the screening test, it is finally cleaned, optically inspected and shipped encapsulated in ESD protective packaging.

EXPORT CONTROL

Since the country of origin of this product (the Czech Republic) is a valid participating member of the Wassenaar Agreement (<http://www.wassenaar.org>) and agrees with the Missile Technology Control Regime (<http://www.mtcr.info>) and the **piDOSE-DCD/FM, piDOSE-DCD/EM, piDOSE-DCD/EK (Space-grade Flight Model, Engineering Model, Evaluation Kit)** functional parameters are considered as a regulated goods, the export is controlled and needs special Export License approved by the Ministry of Industry and Trade of the Czech Republic (the local control entity). The request for the Export License has to be submitted by the manufacturer to the local control entity, based on the binding order, including all the information as: the characteristics of goods, target country (territory), detailed end-user and target application information, etc.

DISCLAIMER

THIS RADIATION MONITORING DEVICE IS NOT INTENDED TO SERVE AS PERSONAL OR LIFE MONITORING OR RELATED RADIATION MONITORING UNIT OR HEALTH-THREATENING ALARM IN RADIATION POLLUTED REGIONS SUCH AS NUCLEAR ACCIDENTS OR NUCLEAR RESEARCH FACILITIES. THIS DEVICE HAS BEEN DEVELOPED WITH IDEA TO SUPPORT THE SMALL SATELLITE COMMUNITY EFFORT IN SPACE RELATED RESEARCH, ENGINEERING AND PEACEFUL CONQUEST OF SPACE. THE MANUFACTURER RESERVES ALL RIGHTS TO DECLINE THE ORDER OF THIS PRODUCT OR PROVIDE ANY FURTHER INFORMATION TO END USERS ASSUMING TO VIOLATE ANY LOCAL OR GLOBAL NATIONAL LAWS BY THIS DEVICE OR INFORMATION MENTIONED IN THIS AND RELATED DOCUMENTS. MANUFACTURER DOES NOT ASSUME ANY LIABILITY ARISING OUT OF THE APPLICATION OR USE OF THIS PRODUCT OR CIRCUIT DESCRIBED HEREIN; NEITHER DOES IT CONVEY ANY LICENSE UNDER ITS PATENT RIGHTS, NOR THE RIGHTS OF OTHERS. MANUFACTURER RESERVES THE RIGHT TO MAKE CHANGES OF THIS PRODUCT DATASHEET WITHOUT FURTHER NOTICE.



Prague, Czech Republic

© 2014-2026 SkyFox Labs, All rights reserved.