



Your easy way to space.



Space-Friendly™
True 2-Channel VHF CubeSat AIS Receiver

piAIS
Product Datasheet

Rev. A/2026

Intended to monitor **Maritime Traffic** from space.

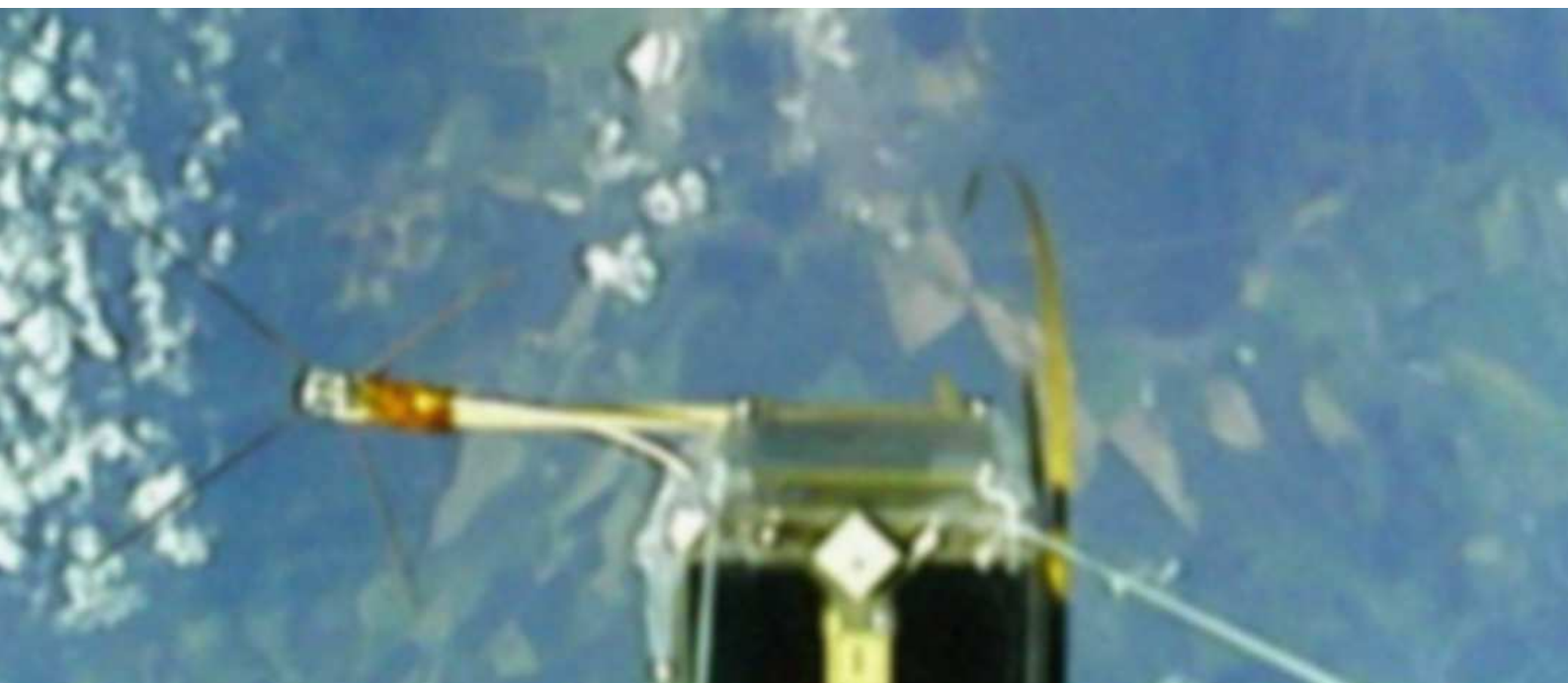

PRODUCT DATA SHEET

piAIS

FEATURES

- World's First Space-Friendly™ True 2-Channel Simultaneous CubeSat AIS VHF Receiver Module
- Automatic Identification System (AIS) Receiver
- 87B, 88B Channels, 161.975 MHz, 162.025 MHz
- 75, 76 Channels, 156.775 MHz, 156.825 MHz
- Dual Band, digital band change via Telecommand
- Packet Counter, Uptime, Temperature, Housekeeping Telemetry Engine
- AIS Messages type 1, 2, 3, 4, 5, 8, 9, 10, 11, 13, 18, 19, 20, 21, 22, 23, 24, 25 and 27 incl. CRC filters
- 72, 96, 160, 168, 360, 424 bit Messages for maximum Maritime Traffic reception rate yield
- ± 3 kHz Doppler shift supported at each channel
- Straightforward use – Plug-and-play device
- Highly Sensitive, Ultra Low Power, World's Lowest Profile
- Sensitivity: up to -106 dBm (at 20% Packet Loss), down to -114 dBm detectable minimum
- SNR required (typical) for message reception: 18-20 dB (non-coherent demodulator)
- Input Antenna Port Noise Floor (no antenna connected): -133 to -134 dBm (typical)
- Up to 1000 km operational slant range, up to 1850 out of 2250 slots @ 168 bit messages throughput (Messages per Minute) at LEO operations link budget conditions (-90 to -104 dBm)
- Intended to: LEO up to h = 600 km or lower
- Power Consumption: 3.0-3.6 V @ 65 mA (210 mW typical)
- Allow Nonstop Operation with conventional 1U CubeSat power budget
- Protocols
 - Downlink: HEX ASCII characters with start, delimiter and end character + CR+LF
 - Uplink: 1-Byte Telecommand
- Easy-to-Implement Data Interface
 - UART 115200-8-N-1, 3V3-CMOS levels
- Low Dimensions, 76x53x12 mm, 55 grams
- Wide temperature range
 - 40°C to +85°C
- Connectors:
 - 2x10, 2 mm pitch Header Board-to-Board stacking connector (Power, Reset, Activity LEDs, UART Data, Interrupt) 1x MCX (VHF Antenna RF signal source)

APPLICATIONS

- Maritime Traffic Monitoring on Small Satellites
- Coastal and Harbor Maritime Traffic Monitoring and satellite software/FlatSat development
- CubeSats, Pico- Nano- Micro-Sats
- Space Science and Engineering & Space STEM

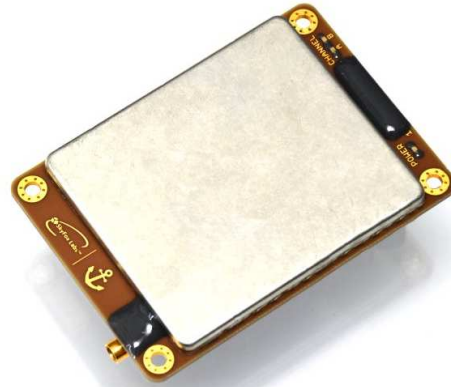

Fig. 1 piAIS/FM, True 2-Channel Dual Band VHF CubeSat AIS Receiver, Flight Model, Top side view.

GENERAL DESCRIPTION

The piAIS is a World's First Space-Friendly True 2-Channel Dual Band CubeSat AIS Receiver working in VHF band as Maritime Automatic Identification System Monitor. The unit provides with data in 72, 96, 160, 168, 360 and 424 bit long messages with CRC check, telemetry message, uptime and packet counter as well as the RSSI and Noise Floor at antenna port input measurements.

The piAIS unit provides data in its natural HEX form with a full length of the respective message type format, representing the full and complete content, with start (*), delimiters (.) and stop (;) characters with CR+LF terminators. The message contains the information about the RF channel the message has been received from (87B = 161.975 MHz, 88B = 162.025 MHz, 75 = 156.775 MHz, 76 = 156.825 MHz), the respective RSSI (signal strength in dBm), order number of the message received (message counter since power up), unit uptime counter and the raw AIS data content.

The Engineering Model (EM) with the same mechanical and electrical properties is available with software limitation to maximum messages per minute. Red Remove Before Flight Finish is applied to prevent interchange with the Flight Model unit. Associated Evaluation Kit with Evaluation Antenna and Parsing Demo Software Application is available for maximum utilization and integration simplicity.

TABLE OF CONTENTS

APPLICATIONS.....	2	PROTOCOLS	7
GENERAL DESCRIPTION.....	2	INPUT COMMAND DESCRIPTION.....	7
TABLE OF CONTENTS	3	OUTPUT DATA DESCRIPTION	8
ABSOLUTE MAXIMUM RATINGS	3	ENGINEERING MODEL	9
PARAMETRIC SPECIFICATION	3	EVALUATION KIT	10
CONNECTORS DESCRIPTION	4	APPLICATION NOTES & RECOMMENDATIONS.....	12
FUNCTIONAL BLOCK DIAGRAM	5	QUALITY ASSURANCE	12
THEORY OF OPERATION.....	5	EXPORT CONTROL.....	13
AIS VHF ANTENNA SYSTEM.....	6	DISCLAIMER	14

ABSOLUTE MAXIMUM RATINGS

V_{DD} to GND.....	-0.3 V to +4.2 V	Other Pins to GND:.....	-0.3 V to +(V _{DD} +0.3) V
DC Input Voltage: V _I	-0.3 V to V _{DD} + 0.3 V (≤ 4.2 V max.)	Maximum RF Input Power:.....	+15 dBm
DC Output Voltage: V _O	-0.3 V to V _{DD} + 0.3 V (≤ 4.2 V max.)	Maximum Output Current to the Active Antenna:.....	50 mA
DC Input Current: I _I at V _I < 0 V or V _I > V _{DD}	±20 mA	Operating Temperature Range:.....	-40°C to +85°C
DC Output Current: I _O at V _O < 0 V or V _O > V _{DD}	±20 mA	Storage Temperature Range:.....	-55°C to +100°C

NOTE: Stresses beyond those listed under “Absolute Maximum Ratings” may cause permanent damage to the device. These are stress ratings only, and functional operation of the device at these or any other conditions beyond those indicated under specification conditions is not implied. Exposure to absolute maximum rated conditions for extended periods may affect device reliability. Voltage values are with respect to system ground terminal.

PARAMETRIC SPECIFICATION

T_A = -40°C to +85°C, V_{DD} = 3.3 V, Unless otherwise noted.

Parameter	Symbol	Min	Typ	Max	Units	Notes/Conditions
Operating Supply Voltage	V _{DD}	3.0	3.3	3.6	V	Input voltage is measured and reported in the Telemetry message.
Operating Supply Current	I _D		65		mA	Operational current is measured and reported in the Telemetry message.
Operating Power Consumption	P _{Oper-Act}		210		mW	
Receiver Noise Floor	N ₀	-128	-133	-134	dBm	Antenna Disconnected, RF port open.
Receiver Maximal Sensitivity	P _{RFMAX}	-108	-113	-114	dBm	Lowest signal power for packet reception.
Receiver 80% Sensitivity	P _{RF80}		-106		dBm	Signal power level at 80% successful reception rate (300 messages per minute, A/B Channel, 168 bit long AIS message with valid CRC), Doppler shift 0 kHz.
Operating Frequency Upper Band A	f _{RFUA}	161.972	161.975	161.978	MHz	Channel A = 87B. 9600bps GFSK, BT=0.4.
Operating Frequency Upper Band B	f _{RFUB}	162.022	162.025	162.028	MHz	Channel B = 88B. 9600bps GFSK, BT=0.4.
Operating Frequency Lower Band A	f _{RFLA}	156.772	156.775	156.778	MHz	Channel A = 75. 9600bps GFSK, BT=0.4.
Operating Frequency Lower Band B	f _{RFLB}	156.822	156.825	156.828	MHz	Channel B = 76. 9600bps GFSK, BT=0.4.
Operating Modulation Bitrate			9600		bps	
Operating BT product			0.4		BT	GMSK modulation as per AIS specification.
Channel Processing Bandwidth	f _{BW}		26		kHz	For both A and B channels.
Operating Doppler shift	f _{Doppler}	-3		+3	kHz	+/- 3kHz per each channel adequate for LEO velocity (7.6 km/s) applications.
Boot up Time	t _{BOOT}		2	3	s	Time since power up to first messages.
Maximum Message per Minute Reception Rate	MPM _{Max}		1850		MPM	Messages per Minute rate, Both Channels combined (925 messages per second per channel), 168 bit AIS Message with valid CRC @ -100dBm each.
RSSI Balance between Channels	dB		0	+/-0.5	dB	RSSI detection level difference between A and B channels. Higher RSSI disbalance can be caused by multipath propagations, keep the antenna out of reflection areas.
GMSK Modem Signal-to-Noise Ratio	SNR	18	20		dB	Typical SNR needed for 80% message error rate.
UART Communication Settings			115200		bps	8 bits, no parity, 1 stop bit.
UART /Interrupt Pre/de-emphasis			100		µs	Time prior the UART transmits the first and after the last data bit.

CONNECTORS DESCRIPTION

The piAIS receiver is connected to the target system via the System Interface (**Two Row**) **2×10 pin** connector header (with **2 mm pitch**). To maximize the pin connection reliability, each signal is provided via two identical pins (doubled). Each pin, its function and direction or manner of use is indicated in the Tab.: 1 below. The connector location within the Flight and Engineering Models is displayed in Fig. 2.

Tab.: 1 The piAIS 2×10 Pin Main Interface Connector Description.

Pin	Name	Input, Output, Power	Description
1, 2	GND	Power	System ground. This pin is internally connected (equal) to pin piAIS (5, 6, 19, 20, MH).
3, 4	VDD	Power	Positive system power input. Positive power supply input, connect to +3.3 V with respect to GND system ground pin. The status is indicated by low power GREEN LED indicator located on the module.
5, 6	GND	Power	System ground. This pin is internally connected (equal) to pin piAIS (1, 2, 19, 20, MH).
7, 8	/RESET	Input	RESET Input. Reset activated by low level, if unused, leave unconnected. LVCMOS compatible.
9, 10	/INT	Output	Interrupt Output. Signal is active low during the message is transmitted at least 100 · s in advance, before the first data byte is sent. Signal is set high after the completion of the data transfer or in idle mode. LVCMOS compatible.
11, 12	CHANNEL A	Output	Channel A Activity Output. Signal is active high during the CRC valid message received through Channel A is transmitted over UART serial port at least 100 · s in advance, in line with INT signal, before the first data byte is sent. Signal is set low after the completion of the data transfer or in idle mode. The status is indicated by low power RED LED indicator located on the module. LVCMOS compatible.
13, 14	CHANNEL B	Output	Channel B Activity Output. Signal is active high during the CRC valid message received through Channel A is transmitted over UART serial port at least 100 · s in advance, in line with INT signal, before the first data byte is sent. Signal is set low after the completion of the data transfer or in idle mode. The status is indicated by low power BLUE LED indicator located on the module. LVCMOS compatible.
15, 16	RXD	Input	Serial Data Input. Telecommands are expected on this pin. Data is expected by standard UART serial transfer at a rate of 115200 bps, no parity, 8 databits, 1 stop bit. LVCMOS compatible.
17, 18	TXD	Output	Serial Data Output. Messages are present on this pin. Data is provided by standard UART serial transfer at a rate of 115200 bps, no parity, 8 databits, 1 stop bit. LVCMOS compatible.
19, 20	GND	Power	System ground. This pin is internally connected (equal) to pin piAIS (1, 2, 5, 6, MH).
MH	Mounting Holes	Power	Mounting Holes, internally DC+AC connected to System ground. This pin is internally connected (equal) to pins piAIS GND (1, 2, 5, 6, 19, 20).

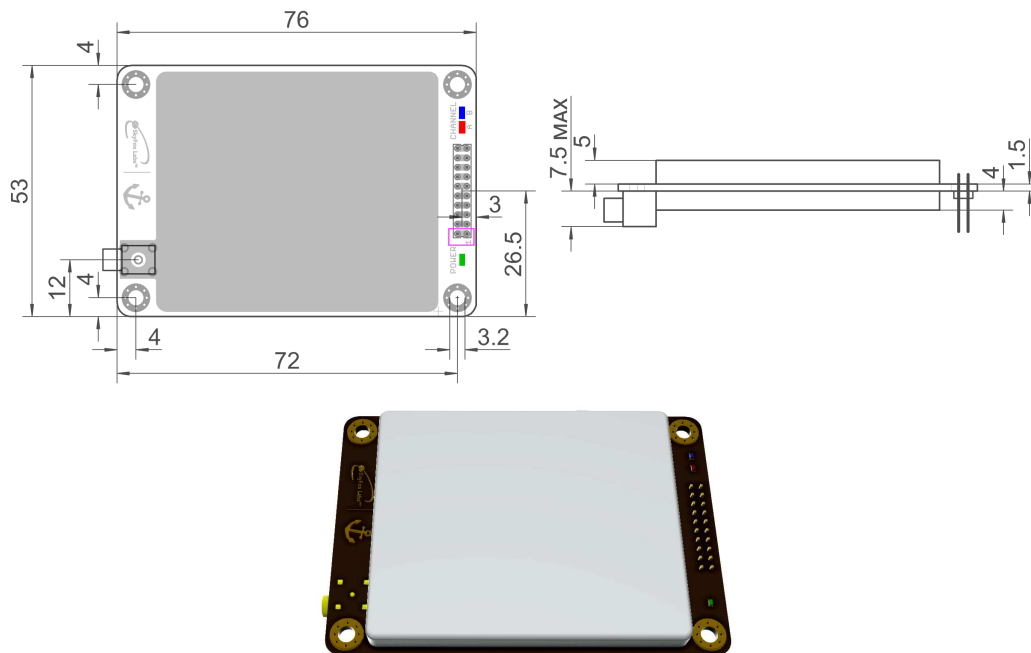

Fig. 2 The piAIS Dimensions, Connectors locations, device footprint, indicating LEDs, Connector Pinout, TOP view (top-left), side view (top-right). STEP model Top view (Bottom). NOTE: Dimensions are shown in millimeters.

The piAIS is equipped with a single antenna input through the 50 Ohm **MCX-Female right angle RF connector** (located under the module - on the bottom side). The Right Angle MCX-Male cable connector is recommended to fit the standard CubeSat structure/envelope. **Corner mounting holes (structural holes for M3 screws)** are metalized and **electrically connected to the system ground potential**.

FUNCTIONAL BLOCK DIAGRAM

The key functional blocks of the piAIS unit are shown in Fig. 3. The passive external 162 MHz VHF antenna system is connected through RF input connector. The set of overload and ESD protective circuitry is followed by the set of RF filters and ultra low noise preamplifier (LNA) chain. Signal is then power splitted in between two separate receivers with GMSK demodulators processing two different channels (A and B). Data NRZI decoders, bit destuffers and deframers are calculated and performed in the main processing core which also performs modem configuration, telemetry measurements (input current, input bus voltage), RSSI readouts, Noise Floor level measurements, packet and uptime counting.

The piAIS unit is fully autonomous and needs no external commanding in order to perform with maximum sensitivity, Doppler shift or modem configuration after the power is applied. The availability of the main +3.3V power is indicated by the Green LED, the activity at the channel A and B is indicated by respective Red and Blue LEDs on the module. Their electrical signal level is also available at respective pins on the main interface connector. The RESET signal is not mandatory to be used and can be left floating, but is available for external Reset activation (active low).

Communication is performed via UART interface, which is accompanied by the interrupt output pin announcing the datagram transmission, in order to provide with advance notification of the data transfer, as the volume of collected data at given baudrate may overload the onboard data storage or message parser.

Note: The deployment or any other mechanical setup of the antenna system (such as burn wire command, pin puller mechanism activation, etc.) once the satellite receiver is in operational mode in orbit must be controlled externally and is not handled nor monitored by the piAIS unit.

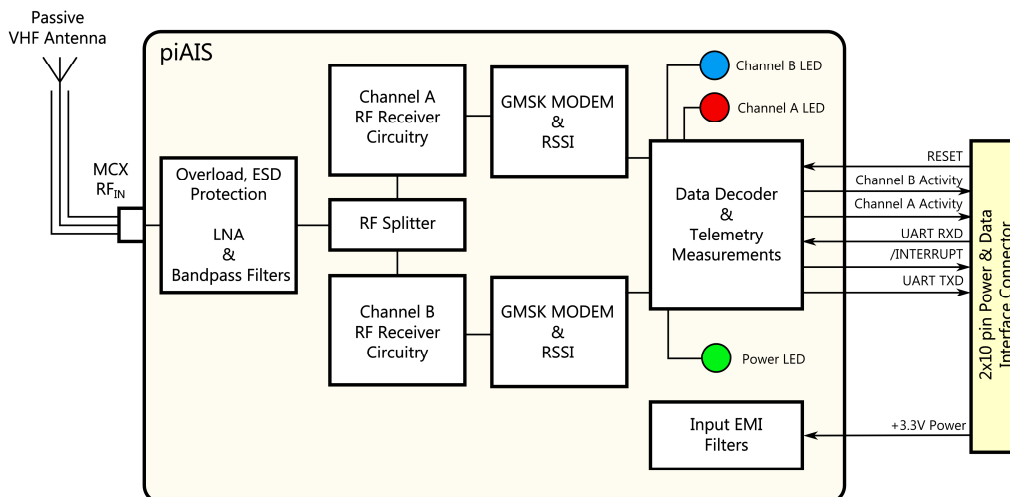

Fig. 3 The piAIS True 2-Channel VHF CubeSat AIS Receiver Block Diagram.

THEORY OF OPERATION

The piAIS unit is working with two separate modems in parallel in order to process both most used Maritime Traffic channels (87B, 88B) in 162 MHz VHF band and “Long Range” channels (75, 76) in 156 MHz VHF band. The signal from the antenna port is filtered and amplified using LNA in order to provide with a sufficient link margin whilst using the same antenna, with no need to process both channels using high sampling rate ADC techniques or high speed broadband FPGA soft cores. In case of the piAIS it is done at a fractional power requirements. The low power 9600 bps BT=0.4 GMSK non-coherent demodulators implemented in the piAIS receiver require about 18 - 20dB SNR in order to capture the whole supported length (424 bit) messages. The link budget expects the power level of -90 to -92 dBm at an altitude of 600 km for Class A transmitters (12.5W) and -98 to -100 dBm for Class B (2W) transmitters.

The angle of operation and the antenna-to-antenna slant range, including the radiation pattern of typically vertical antennas aboard ships (cosine pattern) can increase the free space loss and degrade the link budget, thus the EMI/EMC environment of the receiver (monitored using telemetry measurements Noise Floor data in both channels) as well as the quality of the satellite antenna is crucial for the maximum message reception yield. The lower the operational altitude, the better for the link budget, however the difference between 600 km and 300 km operational altitude is different by only a factor of ~3 dB (two times the distance).

Note that the Class A transmitter, when operated within in-land waterways (rivers, etc.), may be switched to lower power in order to not disturb local traffic and may thus be seen as Class B transmitters/ships with transmit power of 1W, 2W or 5W. The Class A transmitter is typically operated at full power (12.5 W) only on open water areas (seas, oceans,...) far away from reach of coastal service and at low density waterways.

As the receiver needs to operate in orbit with a certain Doppler shift compensation (set in piAIS to $f_{DopplerBW} = 26$ kHz bandwidth), the channel is processed at 6 kHz wider bandwidth than the typical terrestrial AIS equipment (20 kHz), this lowers the 80% packet reception rate from a typical and AIS standards required (-107 dBm) by ~2 dB to levels of -105 to -106 dBm typical for the piAIS receiver unit.

The message filter is applied in data processing core in order to maximize the yield of the data stream capture (Message per Minute rate) to not ruin the processing time for short and long messages, with expected data/signal overlapping/colliding transmitters. The CRC filter as per the AIS standard specification (16 bit) is performed in order to maximize the validity of the data provided. The CRC received over the air and CRC calculated after the proper message reception within the piAIS is however cropped from the output data in order to reduce the amount of data transmitted over UART and is not provided.

After the successful message capture is achieved (data stream demodulated, NRZI decoded, bit destuffed, deframed and CRC checked), the respective Channel A or B indicators are activated (logic level 1) and available on the main interface according to the channel the data is originating from. Additionally, the channel is also indicated in the message header provided by the piAIS. For more, please see the Output Data Description chapter. The antenna input port Noise Floor monitoring is available through periodic notifications in TLM messages, or upon telecommand request as well as other telemetry information (such as input bus voltage, input current, uptime, packet counter).

AIS VHF ANTENNA SYSTEM

Special care shall be taken to design, deploy and operate the proper VHF antenna system aboard the satellite. Due to physical wavelength dimensions, a typical VHF AIS antenna needs to be deployed from the original satellite integration, pre-launch and launch size to the full operational deployed size (in order of ~900 mm tip-to-tip for dipole case). Such event or electro-mechanical principle of antenna deployment must be controlled externally. The piAIS is not providing a trigger electrical signal nor is monitoring any antenna deployment status. As the terrestrial ship transmitter antenna is generating linearly (on the ground vertically) polarized electromagnetic waves, it is desirable to implement xHCP (Right/Left x-Hand Circularly Polarized) VHF antenna system for signal reception aboard the satellite. A basic dipole in a cross-dipole configuration would be a great antenna, which provides the front and back (RHCP, LHCP respectively) circular polarization perpendicular to the plane where dipoles are aligned, attitude controlled using active ADCS. However, the vector circularization is drawing 3 dB gain from the linear-only antenna and it is thus desirable to compensate it such as with the radiator, reflector and director(s) to form the Cross-Yagi directional antenna (yet deployable) system.

Microsatellites can also consider or employ and utilize helical (Helix) antennas for xHCP configuration. Such antenna systems already exist on the CubeSat market, however might be too complex or complicated and less reliable with respect to deployment of a dipole (two monopoles) antenna only. With a cross-dipole antenna (simplest circularly polarized antenna system), the resulting radiation pattern needs to be considered as it may result in various zeros and lobes further decreasing the operational gain. A very good compromise between the gain, polarization and radiation pattern with respect to a size of the 1U, 1.5U, 2U, 3U and 6U standard CubeSat form factors a V-dipole with ~120° dipole element opening angle is recommended and successfully tested, practically forming an omnidirectional pattern (yet still with a majority of linear vector).



NOTE: *Work closely to monitor the Noise Floor levels detected by the piAIS TLM (telemetry) measurements in order to be able to reach the operating link budget levels minus the Modem SNR requirement (18-20dB) during the satellite development and operational mode tests. In the best case, perform the tests in anechoic chamber or far away from human-made or artificial EMI/EMC sources. Pay special attention to the nearest source of potential EMI/EMC sources aboard the satellite platform itself. As a basic rule, the Noise Floor needs to be -110 to -112 dBm or better for Class A transmitters at 600 km altitude and -118 to -120 dBm for Class B or Class A transmitters operated in-land at low power mode, respectively.*

With a full length (not further length-reduced for easier antenna stowing for pre-flight configuration) of the dipole arms and with no deployment mechanism (burnwires, pin-pullers, etc.) or antenna loading (dipole arm shorting) RF components as a demonstration of the principle a special antenna module is provided as ready-

made product called *piAIS/EA Evaluation Antenna*, fitting the Z+/- side CubeSat wall. The module is depicted in Fig. 4. The module with arms length trimmed to resonant frequency of 156-162 MHz mounted on a CubeSat conductive aluminum structure in open space conditions is equipped further with the 50 ohm de-symmetrization balun and MCX RF connector. The interconnect MCX-MCX coaxial cable is a part of the Antenna module set with a maximum length of 500 mm.

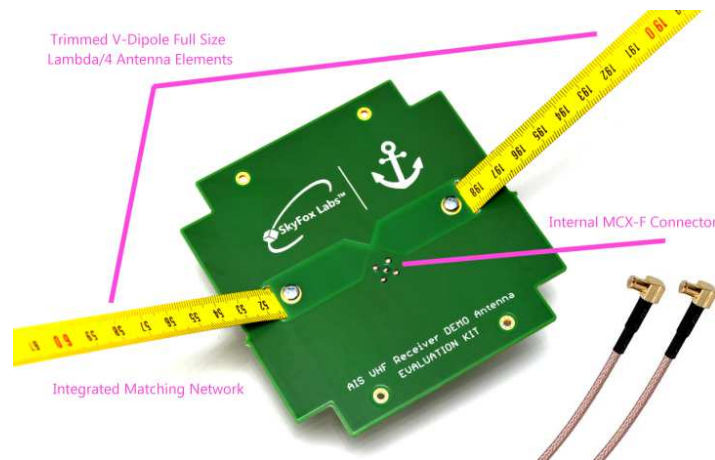

Fig. 4 The piAIS/EA 120° angle V-dipole Evaluation Antenna module (full dipole arms length not displayed).



CAUTION: As some configurations of the VHF antenna elements may be left floating with respect to local ground (with no DC link in between active radiator and ground counterpart), the piAIS receiver unit implements 100 kOhm input impedance shunt in order to help continuously discharge potential ion-electron charge pickup during the flight in LEO plasma environment. A DC short at the third-party antenna system RF feed (antenna output towards the piAIS input) is fully supported by the piAIS and can be implemented (such as DC short via baluns, LC-matching components, impedance matching feeds, etc.). No active DC bias is applied to the piAIS antenna input with respect to system ground potential (coaxial ground).

PROTOCOLS

The physical communication is realized via the standard UART data interface. The baud rate is set to 115200 bps, no parity, 8 data bits, 1 stop bit. Logical levels are equal to LVCMOS levels as defined in JEDEC JESD8C.01 standard. In order to provide with no binary data (human readable ASCII characters) the data is encoded into HEX ASCII datagrams with start, delimiters and stop character with CR+LF.

INPUT COMMAND DESCRIPTION

Commanding of the piAIS is performed using single-byte Telecommands set (TC). Their description is given in Tab.: 2. For a nominal operations, there is no need to upload/uplink any telecommands. The unit is performing in full mode after the power is applied. The TC set is available to force internal reset and/or read out the telemetry information more often than during regular one minute automatic cycle. It is case insensitive.

Tab.: 2 The piAIS Telecommand (TC) Set Table.

ASCII Character	Telecommand Description
Reset Telecommands	
r	Activates the unit watchdog timer runaway event and initiate reset.
R	Activates the unit watchdog timer runaway event and initiate reset.
Telemetry Telecommands	
t	Returns TLM message with telemetry measurements, packet counter and uptime information.
T	Returns TLM message with telemetry measurements, packet counter and uptime information.
Digital Band Switching Telecommands	
u	Sets the receiver to Upper band tuning 87B, 88B, 161.975 MHz and 162.025 MHz.
U	Sets the receiver to Upper band tuning 87B, 88B, 161.975 MHz and 162.025 MHz.
Digital Band Switching Telecommands	
l	Sets the receiver to Lower band tuning 75, 76, 156.775 MHz and 156.825 MHz. (lower case L)
L	Sets the receiver to Lower band tuning 75, 76, 156.775 MHz and 156.825 MHz.

OUTPUT DATA DESCRIPTION

In order to prevent providing the output data stream in binary form which may cause string shifts and string bytes order ambiguities within the Onboard Computer Data storage or onboard parser, the raw output data is encoded in ASCII character set only with standard CR+LF stop bytes. All output messages starts with asterisk '*' (0x2Ah) as a Start Character followed by the data fields separated by comma delimiters ',' (0x2Ch), ended by semicolon ';' (0x3Bh) End Character, terminated by CR+LF (0x13h + 0x10h, ↵) bytes as the message End of Transmission. A variable message length is provided depending on message type.

The first type of message is telemetry, indicated by three characters "TLM" after the first (asterisk) start byte. This message type is provided in fixed length. Temperature 0°C is reported as +00°C, +1°C as +01°C and negative temperature such as -1°C is reported as -01°C. Detailed content is described in Tab.: 3.

TLM Telemetry Output Example sent over UART Interface (59 bytes + CR+LF = 61 B)

```
*TLM, 3.22V, 065.0mA, +27°C, 000006E8, 0000279C, -115.5, -116.0, U; ↵
```

Tab.: 3 piAIS TLM message content data format, including decoded value examples.

String Location	Amount of byte Positions	Value HEX	Value DEC	Physical Value	Meaning	Value Range	Note
0	1	0x2Ah	42	*	Start character	-	Asterisk character acting as Message start.
1 to 3	3	-	-	TLM	Message type identifier	-	TLM indicates Telemetry message.
4	1	0x2Ch	44	,	Delimiter	-	Comma character acting as delimiter.
5 to 9	5	-	-	3.22 V	Input Bus Voltage	0 to 4.20 V	Input Bus Voltage in V, fixed length.
10	1	0x2Ch	44	,	Delimiter	-	Comma character acting as delimiter.
11 to 17	7	-	-	65.0 mA	Input Bus Current	0 to 122.4 mA	Input Bus Current in mA, fixed length.
18	1	0x2Ch	44	,	Delimiter	-	Comma character acting as delimiter.
19 to 23	5	-	-	+27°C	Temperature	-40 to +85°C	Unit core Temperature in °C, decadic, fixed length and sign (+ or -). 0°C sent as 00°C.
24	1	0x2Ch	44	,	Delimiter	-	Comma character acting as delimiter.
25 to 32	8	-	1768	0x000006E8h	Message counter	0h to FFFFFFFFh	Amount of messages sent, in HEX form, fixed length.
33	1	0x2Ch	44	,	Delimiter	-	Comma character acting as delimiter.
34 to 41	8	-	10140	0x0000279Ch	Unit Uptime in seconds.	0h to FFFFFFFFh	Unit Uptime, in HEX form, fixed length.
42	1	0x2Ch	44	,	Delimiter	-	Comma character acting as delimiter.
43 to 48	6	-	-115.5	-	dBm	-134.0 to -020.0	Noise Floor in Channel A (87B) in dBm, fixed length.
49	1	0x2Ch	44	,	Delimiter	-	Comma character acting as delimiter.
50 to 55	6	-	-116	-	dBm	-134.0 to -020.0	Noise Floor in Channel B (88B) in dBm, fixed length.
56	1	0x3Bh	59	;	Delimiter	-	Semicolon character acting as message stream length.
57	1	0x55	85	U	Band Selected	L, U	U = Upper Band, L = Lower Band
58	1	0x3Bh	59	;	End character	-	Semicolon character acting as message stream length.
59 to 60	2	0x13h, 0x10h	19, 16	↵	CR+LF	-	Carriage Return and Line Feed end of line.

The second type of message is the AIS Message received after the proper CRC calculation filter check. It is composed by the start asterisk character initiating the transmission, followed by the name of the channel in which the message was received and processed (either 87B, 88B, 75, 76 at 161.975 MHz, 162.025 MHz, 156.775 MHz, 156.825 MHz respectively). The RSSI measurement is followed after the comma delimiter in dBm and corresponds to the power level the message was received at. The number of the message (message counter) is a follow up value, sent in HEX form. Then after another delimiter the RAW HEX data of the received AIS message is provided, closed by the semicolon and CR+LF.

As the piAIS processes different Message types, the length of the AIS data field is variable, depending on the message type, ranging from 72 to 424 bits, represented by respective amounts of ASCII HEX values. I.e. 96 bits messages are represented by 72b / 8b = 9B, 9B × 2 = 18 ASCII characters, whilst the longest supported AIS 424 bit messages are represented by 424b / 8b = 53B, 53B × 2 = 106 ASCII characters. Typical ship AIS data field carry 168 bits of data. Detailed content is described in Tab.: 4.

87B/88B/75-/76- AIS Data Output Example sent over UART Interface (64 bytes + CR+LF = 66B)

***87B, -081.0, 000006EF, 1000A54F107E940C09A41073D26729FA6BC00808CA; ←↵**

Tab.: 4 AIS Data Output Description. ASCII HEX data format, (Base Station Report: Message Type 4).

String Location	Amount of byte Positions	Value HEX	Value DEC	Physical Value	Meaning	Value Range	Note
0	1	0x2Ah	42	*	Start character	-	Asterisk character acting as Message start.
1 to 3	3	-	-	87B, 88B, 75-, 76-	Channel source of data	-	87B = 161.975 MHz, 88B = 162.025 MHz, 75- = 156.775 MHz, 76- = 156.825 MHz.
4	1	0x2Ch	44	,	Delimiter	-	Comma character acting as delimiter.
5 to 10	6	-	-	-81.0 dBm	RSSI in dBm	-20 to -114dBm	Received Signal Strength Indicator (RSSI), the respective Noise Floor is thus at least -99 to 101dBm (i.e. by SNR of 18-20 dB lower).
11	1	0x2Ch	44	,	Delimiter	-	Comma character acting as delimiter.
12 to 19	8	-	-	0x000006EFh	Message counter	0h to FFFFFFFFh	1775th message. Fixed length, HEX value.
20	1	0x2Ch	44	,	Delimiter	-	Comma character acting as delimiter.
21 to 62	42				AIS message payload data according to the AIS Message type. Message types supported: 1, 2, 3, 4, 5, 8, 9, 10, 11, 13, 18, 19, 20, 21, 22, 23, 24, 25, 27. Variable length.	Message Type: 10, 13 = 72b = 9Bx2 = 18 characters, 27 = 96b = 12Bx2 = 24 characters, 20, 23 = 160b = 20Bx2 = 40 characters, 1, 2, 3, 4, 8, 9, 11, 18, 22, 24, 25, 27 = 168b = 21Bx2 = 42 characters, 19 = 312b = 39Bx2 = 78 characters, 21 = 360b = 45Bx2 = 90 characters, 5 = 424 bits = 53Bx2 = 106 characters.	Two characters represents HEX value of a single byte, i.e. "5A" = 0x5Ah = 0b01011010. Bit order and bit MSB and LSB is representing the direct over the air order as per AIS specification. The Example data starts with 0x10h, which represents binary value of 0b00010000. According to the AIS data specification, the first 6 bits represents the AIS Message type, in this case: 0b000100 = 4 (Decadic), or AIS Message Type 4 (Base Station Report), which is 168bit long (sent as 42 HEX characters).
63	1	0x3Bh	59	;	End character	-	Semicolon character acting as message stream length.
64 to 65	2	0x13h, 0x10h	19, 16	←↵	CR+LF	-	Carriage Return and Line Feed end of line.

ENGINEERING MODEL

The piAIS is available in the Engineering Model (/EM) grade version in order to support the Flat Sat design, as well as the onboard data output parsing software development (such as ADCS, OBC, etc.). A special care have to be taken to the EMC/EMI environment in order to maximize the receiver sensitivity yield. To test whether the satellite bus subsystems, Flat Sat or satellite Qualification Model (magnetorquers, MPPT solar controllers, DC/DC converters, transmitters, mixers, local oscillators, etc.) are not affecting the piAIS receiver Noise Floor, the Engineering Model grade with identical electrical and RF properties is a perfect tool to perform an RF/EMI survey. **It is highly recommended to run the test before the flight and observe whether the fully operational satellite is not limiting the maximum available Noise Floor values and/or unit functionality.**

The red **Remove Before Flight** finish reminds to replace the unit with the Flight Model grade unit suitable for the environment of space, in case it is used on Flight Model of the satellite. The firmware of the EM model is modified by the packet rate limitations and is also not intended for flight (not intended for vacuum use).

EVALUATION KIT

The piAIS Evaluation Kit in Fig. 5 has been developed to support the implementation together with the onboard parsing software development in engineering, development and breadboarding (AIV, AIT) phases. It enables to connect and power the piAIS from the USB port easily. Current consumption measurement and output data waveforms can be captured by conventional Ammeter and Scope probe on top of the Telemetry messages provided over UART, using current sensing and serial port pin headers. Indicating LEDs inform directly about the signal statuses and unit activity. The device is not intended for spaceflight.

The AIS VHF Receiver DEMO Antenna as a source of proper RF signal, unbalanced (connected via coaxial cable), trimmed to desired 156-162 MHz band and pre-tuned, is available to set up a complete signal chain (antenna - receiver - serial link - PC/computer with UART interface).

The associated parsing software for PC is available to display, uplink (send) telecommands and plot all data and features in real time.

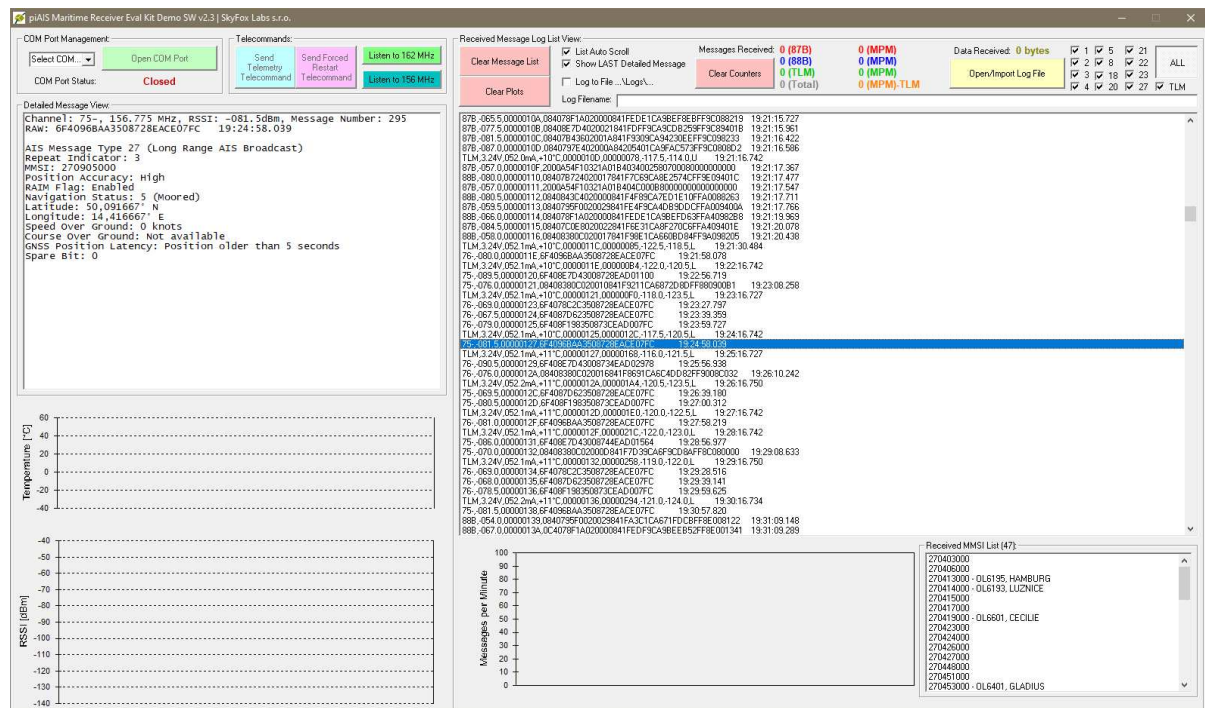
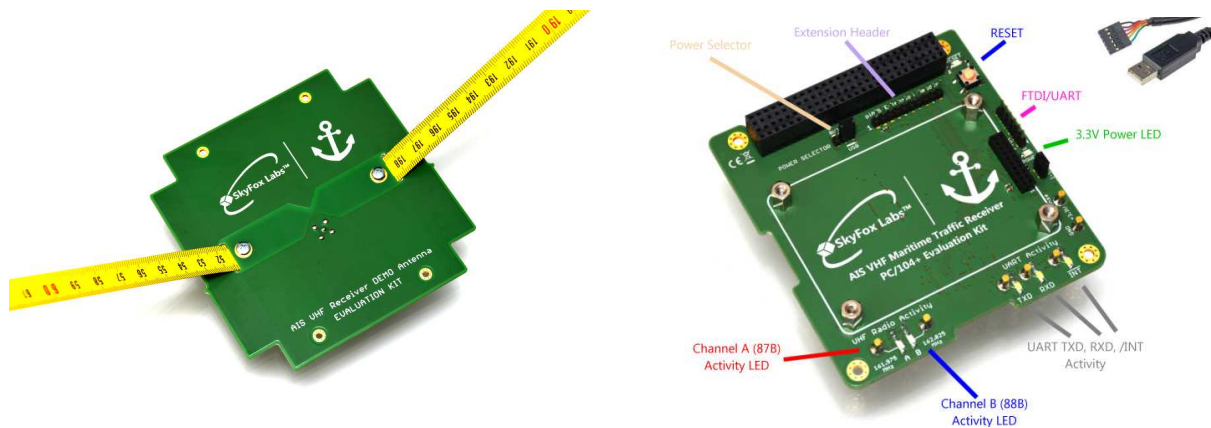

Fig. 5 The piAIS/EA Evaluation Antenna (top-left), piAIS/EK PC/104+ Evaluation Kit PCB Unit for development purposes (top-right), units are not intended for flight, piAIS Maritime Receiver Eval Kit Demo Software for Windows®.

Schematic diagram in Fig. 6 of the piAIS/EK Evaluation Kit describes the basic circuit diagram and pinout for the key signals on the unit.

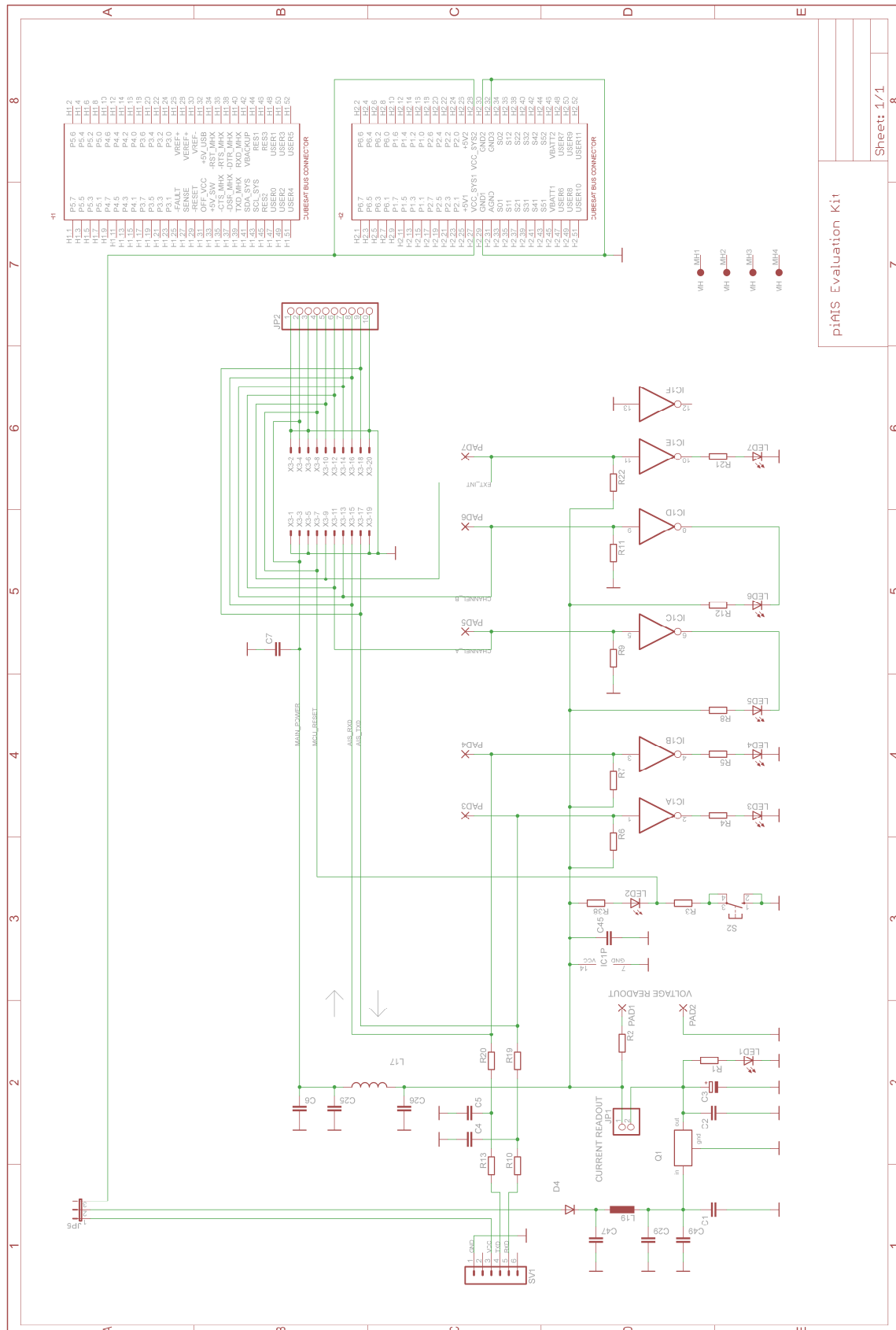

Fig. 6 piAIS/EK Evaluation Kit schematics.

APPLICATION NOTES & RECOMMENDATIONS

EMC CONSIDERATIONS

As the size of the small satellites imply the high level of integration of different electronic devices (switch mode power supplies, high speed digital electronics, pulse-width modulated electromagnetic actuators, etc.) into a limited satellite structure volume containing potential sources of disturbing signals, the electromagnetic susceptibility and compatibility is critical for implementation of any subsystems sensitive to electromagnetic radiation.

Proper ground planes and PCB design rules minimizing the radiated and conducted emissions shall be applied within the whole small satellite structure, including custom payloads, conventional (Communication and Data Handling, Power Supply and Power Distribution, Onboard Computer, Attitude Determination and Control) and third party electronic subsystems. The small satellite electronics should be properly designed to not disturb the piAIS receiver input with harmonic frequencies falling to the VHF (156 and 162 MHz) frequency band.



NOTE: The N_0 (Noise Floor) parameter provided in the Telemetry Output message (TLM) can be exploited as a diagnosis tool to check whether the EMC issues affect the piAIS reception capability (especially satellite mounted antenna as a source of the AIS signal, such test may require open sky testing). **Always observe the N_0 (Noise Floor) levels and switch On/Off each electronic subsystem to identify the potential source of the disturbance. If needed, using open-sky signal level and quality!**

ANTENNA LOCATION

Special care should be taken to the interference with the small satellite communication subsystem, as an active electronic device radiating the high power electromagnetic waves. The manufacturer recommends installing the AIS antenna as far from the (transmitting) communication antennas as possible.

Be sure to test the target small satellite subsystems against affecting the performance of the piAIS receiver under all satellite operation conditions. Keep in mind the receiver may be sensitive to harmonics of the downlink (transmitter) frequency (i.e. 156/162 MHz /9, /8, /7, /6, /5 /4, /3, /2, etc.) or uplink receiver spurious emissions, local MPPT EMC radiation, magnetorquer PWM EMC radiation, etc. **It is highly recommended to perform full functional test on the flight or flight-representative satellite model to ensure the EMC compatibility!!!**

QUALITY ASSURANCE

GENERAL INFORMATION

Since the piAIS unit has been designed for the operation in harsh space environment as a specially featured electronic device based on Commercial Off-the-Shelf (COTS) components, the special care is taken to follow the standardized space-grade product assembly procedures, materials and components where possible (i.e. no Radiation Hardened integrated circuit are used).

MATERIALS

Components are soldered on the 6-layers FR-4 PCB, using 60/40% (Tin/Lead) compound. No PCB solder mask is used on the Flight Model units to exclude the outgassing. A conformal coating is applied instead. Engineering Models contains red solder mask and is not intended for flight/vacuum environment. The volume of the gold is limited to a minimum by implementing the only gold-plated MCX connectors providing excellent RF and contacting performance and main interface connector for improved conductivity.

Vacuum-proof electronic components from ESA and NASA-preferred space-grade vendors are used (i.e. no electrolytic capacitors) in industrial or military temperature grade, where possible.

PACKAGING & SHIPPING

Once the piAIS successfully passes the screening, electrical, radio and firmware test, it is finally cleaned, optically inspected and shipped encapsulated in ESD protective packaging.

EXPORT CONTROL

Since the country of origin of this product (the Czech Republic) is a valid participating member of the Wassenaar Agreement (<http://www.wassenaar.org>) and agrees with the Missile Technology Control Regime (<http://www.mtcr.info>) and the **piAIS/FM, piAIS/EM, piAIS/EK, piAIS/EA (Space-grade Flight Model, Engineering Model, Evaluation Kit, Evaluation Antenna)** functional parameters are considered as a regulated (Dual Use) goods, the export is controlled and needs the Export License for export outside the European Union. No military or military-related end use and end-users are allowed.

DISCLAIMER

THIS DEVICE HAS BEEN DEVELOPED WITH IDEA TO SUPPORT THE SMALL SATELLITE COMMUNITY EFFORT IN SPACE RELATED RESEARCH, ENGINEERING AND PEACEFUL CONQUEST OF SPACE. THE MANUFACTURER RESERVES ALL RIGHTS TO DECLINE THE ORDER OF THIS PRODUCT OR PROVIDE ANY FURTHER INFORMATION TO END USERS ASSUMING TO VIOLATE ANY LOCAL OR GLOBAL NATIONAL LAWS BY THIS DEVICE OR INFORMATION MENTIONED IN THIS AND RELATED DOCUMENTS. MANUFACTURER DOES NOT ASSUME ANY LIABILITY ARISING OUT OF THE APPLICATION OR USE OF THIS PRODUCT OR CIRCUIT DESCRIBED HEREIN; NEITHER DOES IT CONVEY ANY LICENSE UNDER ITS PATENT RIGHTS, NOR THE RIGHTS OF OTHERS. MANUFACTURER RESERVES THE RIGHT TO MAKE CHANGES OF THIS PRODUCT DATASHEET WITHOUT FURTHER NOTICE. THE UNIT MUST NOT BE USED IN ANY SAFETY-CRITICAL APPLICATION, OR MILITARY-RELATED, OR BY ARMED FORCES, OR BY POLICE GUARDS, OR IN NUCLEAR FACILITIES, OR IN RELATION TO OIL AND GAS MINING, ON LAUNCHERS, MISSILES, TARGET DRONES, WEAPONS OF MASS DESTRUCTION, OR GOVERNMENTAL END USE OR END USER. SAFETY-CRITICAL SYSTEMS ARE THOSE SYSTEMS WHOSE FAILURE COULD RESULT IN LOSS OF LIFE, SIGNIFICANT PROPERTY DAMAGE OR DAMAGE TO THE ENVIRONMENT. THE LIST CONTAINS MOST IMPORTANT AREAS OF PROHIBITED USE AND IS NOT COMPLETE. FOR MORE DETAILS, PLEASE CONTACT FACTORY.



Prague, Czech Republic

© 2014-2026 SkyFox Labs, All rights reserved.